



SIS - Standardiseringskommissionen i Sverige

Handläggande organ

SMS, SVERIGES MEKANSTANDARDISERING

SVENSK STANDARD SS-ISO 7648

Fastställt

1989-12-06

Utgåva

1

Sida

1 (9)

Registrering

SMS reg 464.112

SIS FASTSTÄLLER OCH UTGER SVENSK STANDARD SAMT SÄLJER NATIONELLA OCH INTERNATIONELLA STANDARDPUBLIKATIONER ©

Vägfordon — Förbränningsmotorer — Svänghjulskåpor — Mått och toleranser

Denna standard utgörs av den engelska versionen av den internationella standarden ISO 7648:1987.

Svänghjulskåpor enligt denna standard godkändes inte av Sverige vid den internationella remissbehandlingen, eftersom det vanligaste utförandet av hjälplagringen i svänghjulskåpan inte har medtagits i figur 3.

Användare av denna standard bör uppmärksamma att internationella standarder ibland revideras och att varje referens till annan internationell standard innebär referens till dess senaste utgåva, om inget annat bestämts.

Följande dokument, som åberopas i denna standard, är överförda till svenska standarder:

- ISO 273:1979 = SS-ISO 273, utg 1 (SMS reg 15.225), Fästelement – Frigående hål för skruvar – Metriska ISO-gängor, E + Sv
- ISO 1101:1983 = SS-ISO 1101, utg 1 (SMS reg 12.55), Form- och lägetoleranser – Allmänt, definitioner, symboler, ritningsangivning, E + Sv

E betecknar engelsk text, Sv svensk.

E indicates English, Sv Swedish text.

Flywheel housings for reciprocating internal combustion engines — Nominal dimensions and tolerances

This Swedish standard consists of the English version of the International Standard ISO 7648:1987.

Flywheel housings according to this standard were not approved by Sweden in the international circulation for comment, since the most common design of the pilot bearing bore in the flywheel housing is not shown in figure 3.

Users should note that all International Standards undergo revision from time to time and that any reference made herein to any other International Standard implies its latest edition, unless otherwise stated.

The following documents, referred to in this standard, have been adopted in Swedish standards:

UDK 621.43-562:629.11

Standarder kan beställas hos SIS som även lämnar allmänna upplysningar om svensk och utländsk standard.
Postadress: SIS, Box 3295, 103 66 STOCKHOLM
Telefon: 08 - 613 52 00. Telefax: 08 - 11 70 35

Upplysningar om sakinnehållet i standarden lämnas av SMS.
Telefon: 08 - 783 80 00. Telefax: 08 - 667 85 42

Prisgrupp L

Tryckt i februari 1990

Flywheel housings for reciprocating internal combustion engines — Nominal dimensions and tolerances

1 Scope and field of application

This International Standard specifies the nominal dimensions and tolerances of flywheel housings for reciprocating internal combustion engines, in particular those which affect interchangeability with mating parts.

It applies to reciprocating internal combustion engines except engines for aircraft and passenger cars.

Flywheel housings of size codes 1 to 4 are recommended for commercial vehicles and buses.

2 References

ISO 273, *Fasteners — Clearance holes for bolts and screws.*

ISO 1101, *Technical drawings — Geometrical tolerancing — Tolerancing of form, orientation, location and run-out — Generalities, definitions, symbols, indications on drawings.*

ISO 7649, *Commercial vehicles — Clutch housings for internal combustion engines — Nominal dimensions and tolerances.*¹⁾

3 Nominal dimensions and tolerances

3.1 Flywheel housing

See figure 1 and table 1.

1) At present at the stage of draft.

Table 1 – Flywheel housing dimensions and tolerances

Dimensions in millimetres

Size code	A		Run-out (assembled flywheel housing) <i>t</i>	B nom.	D* min.
	nom.	tol.			
02	1 245	+ 0,25 0	not applicable	1 400	10
01	1 010,00	+ 0,25 0		1 165	10
00	787,40	+ 0,25 0		0,47	883
0	647,70	+ 0,25 0	0,39	711	8
1/2	584,20	+ 0,20 0	0,35	648	8
1	511,18	+ 0,13 0	0,31	553	8
2	447,68	+ 0,13 0	0,27	489	8
3	409,58	+ 0,13 0	0,25	451	8
4	361,95	+ 0,13 0	0,25	404	8
5	314,32	+ 0,13 0	0,25	356	8
6	266,70	+ 0,13 0	0,25	308	8

* Dimension *D* relates to flywheel housings without rubber sealing. However, this dimension may be increased if a rubber seal is necessary.

NOTE – Run-out tolerances *t* shall be measured on the assembled engine mounted on its supports in accordance with the annex. (See ISO 1101 for definition of run-out.)

Dimensions in millimetres

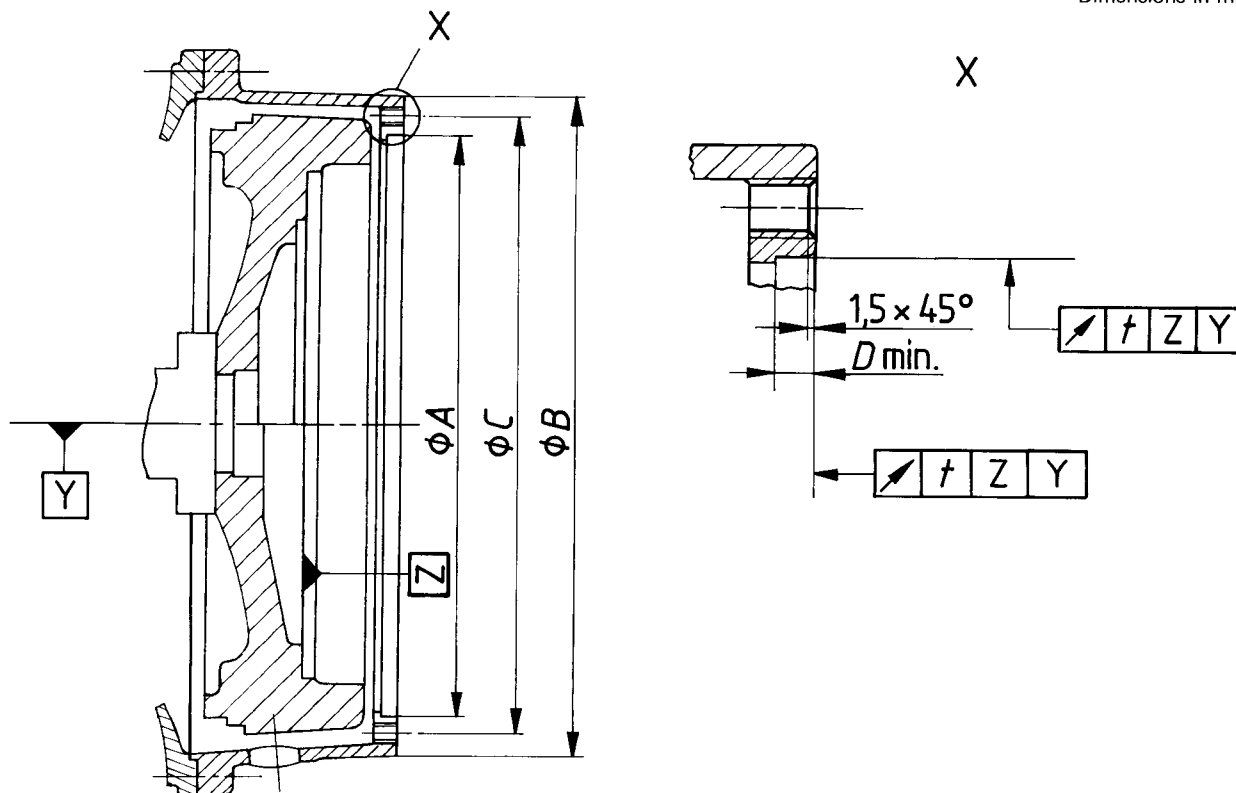

Figure 1 – Flywheel housing

3.2 Bolt or screw spacing and size

3.2.1 Dimensions and tolerances

See figure 1 and table 2.

Table 2 – Tapped holes and bolt or screw spacing and dimensions

Size code	Tapped holes		Recommended thread engagement		C nom. mm (see figures 1 and 2)
	Number	Size			
02	24	M16	For cast iron flywheel housing 1,5 × ø nom. of bolt or screw	For aluminium flywheel housing 2 × ø nom. of bolt or screw	1 340,00
01	24	M16			1 105,00
00	16	M12			850,90
0	16	M12			679,45
1/2	12	M12			619,12
1	12	M10*			530,22
2	12	M10	466,72		
3	12	M10	428,62		
4	12	M10	381,00		
5	8	M10	333,38		
6	8	M10	285,75		

* M12 may be used for high engine torque applications.

NOTE – 24 tapped holes are optional for aluminium flywheel housings of size code 1.

3.2.2 Spacing

Tapped holes shall be spaced equally on each side of the vertical and horizontal axis lines as shown in figure 2.

Dimensions in millimetres

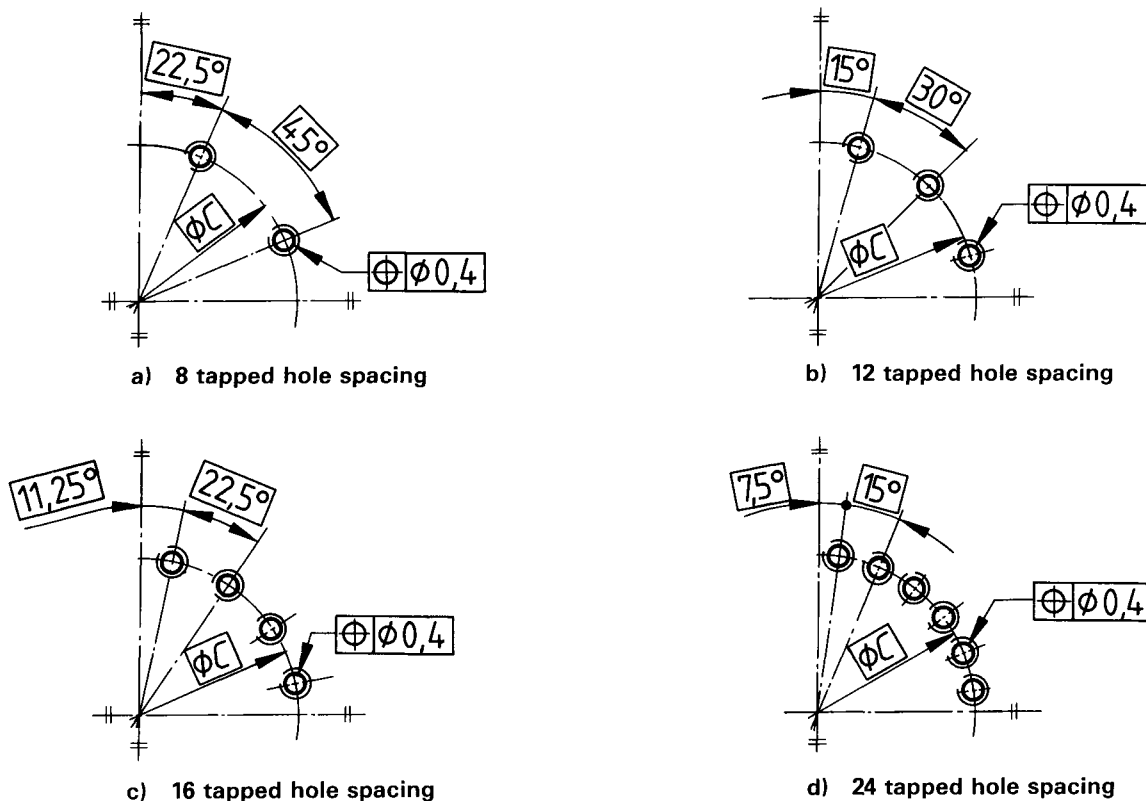

Figure 2 – Bolt or screw hole spacing

4 Relationship of pilot bearing bore to flywheel housing

The depth of the pilot bearing bore (see *E* in figure 3) extends from the flywheel housing face to a shoulder in the flywheel, to a shoulder within the crankshaft or to the crankshaft flange face.

Table 3 — Depth of pilot bearing bore

Dimensions in millimetres

Size code	<i>E</i> nom.	<i>E</i> nom. optional for:	
		double plate clutches when extra-heavy flywheel is used	overcentre clutch
02	265	—	—
01	265	—	—
00	100	133,4	—
0	100	133,4	—
1/2	100	133,4	—
1	100 — 112 ¹⁾	133,4	—
2	100 — 112 ¹⁾	—	—
3	100	—	—
4	100	—	71
5	71	—	100
6	71	—	—

1) An *E* dimension of 112 mm is optional for flywheel housing size codes 1 and 2 when the clutch shaft bearing is located in the pilot bearing bore of the flywheel or crankshaft end, i.e. when the bearing is not located in a separate carrier.

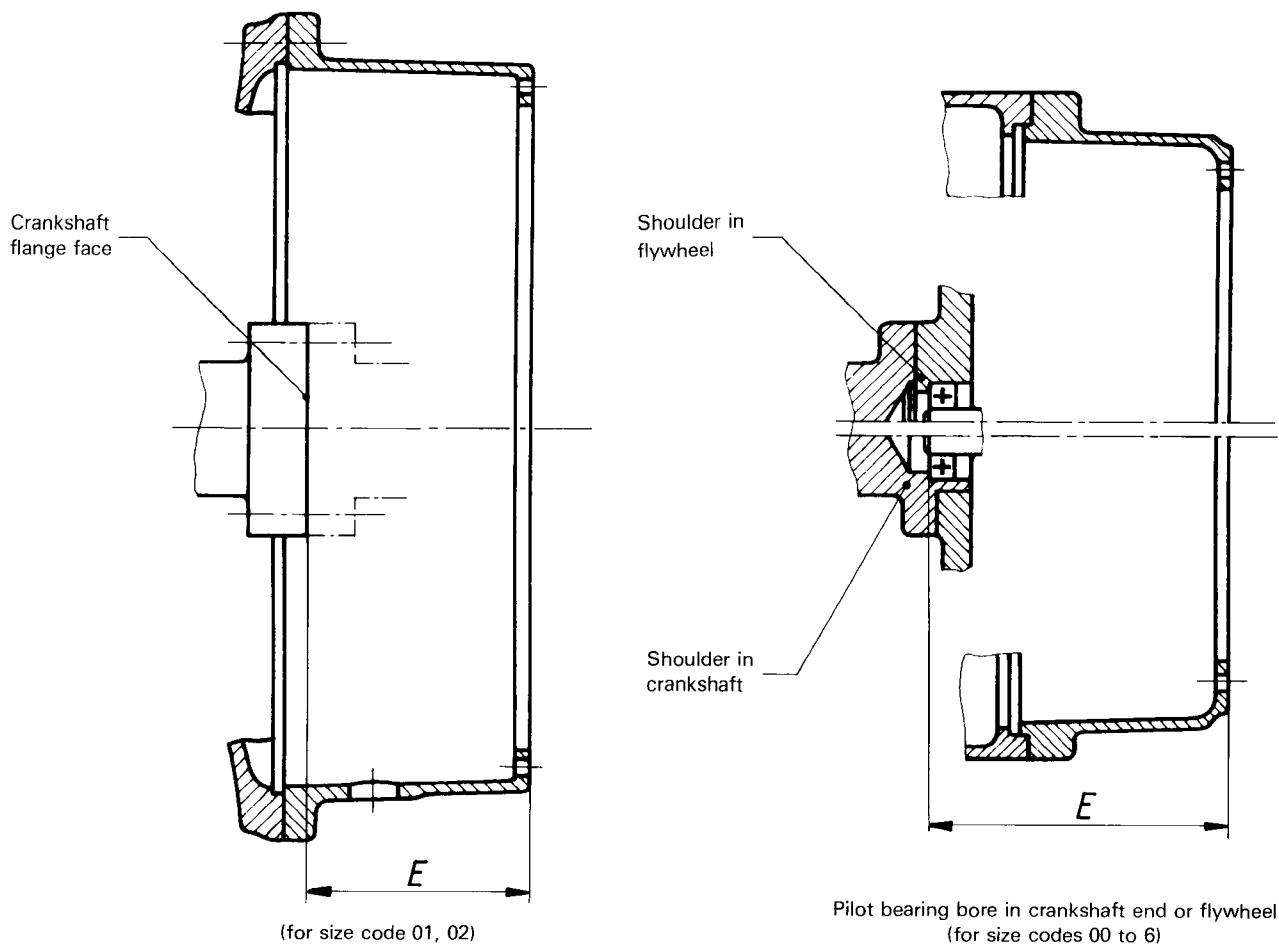

Figure 3 — Depth of pilot bearing bore

5 Mating part flange (for example, clutch housings)

The dimensions and tolerances of clutch housings for reciprocating internal combustion engines are given in ISO 7649.

Limits and fits of the pilot diameter of the mating part are at the discretion of the manufacturer of that component. The manufacturer shall also specify the tolerances of form and position of the mating part flange.

The clearance holes of the mating part flange shall have the same location as specified under 3.2.2 and shall be in accordance with ISO 273.