

# SVENSK STANDARD

## SS-ISO 15:2017



Fastställt/Approved: 2017-12-08  
Publicerad/Published: 2017-12-08  
Utgåva/Edition: 1  
Språk/Language: engelska/English  
ICS: 21.100.20

---

### **Rullningslager – Radiallager – Huvudmått, dimensionsplan (ISO 15:2017, IDT)**

### **Rolling bearings – Radial bearings – Boundary dimensions, general plan (ISO 15:2017, IDT)**

This preview is downloaded from [www.sis.se](http://www.sis.se). Buy the entire standard via <https://www.sis.se/std-8029993>

# Standarder får världen att fungera

*SIS (Swedish Standards Institute) är en fristående ideell förening med medlemmar från både privat och offentlig sektor. Vi är en del av det europeiska och globala nätverk som utarbetar internationella standarder. Standarder är dokumenterad kunskap utvecklad av framstående aktörer inom industri, näringsliv och samhälle och befrämjar handel över gränser, bidrar till att processer och produkter blir säkrare samt effektiviserar din verksamhet.*

## Delta och påverka

Som medlem i SIS har du möjlighet att påverka framtida standarder inom ditt område på nationell, europeisk och global nivå. Du får samtidigt tillgång till tidig information om utvecklingen inom din bransch.

## Ta del av det färdiga arbetet

Vi erbjuder våra kunder allt som rör standarder och deras tillämpning. Hos oss kan du köpa alla publikationer du behöver – allt från enskilda standarder, tekniska rapporter och standardpaket till handböcker och onlinetjänster. Genom vår webbtjänst e-nav får du tillgång till ett lättnavigerat bibliotek där alla standarder som är aktuella för ditt företag finns tillgängliga. Standarder och handböcker är källor till kunskap. Vi säljer dem.

## Utveckla din kompetens och lyckas bättre i ditt arbete

Hos SIS kan du gå öppna eller företagsinterna utbildningar kring innehåll och tillämpning av standarder. Genom vår närhet till den internationella utvecklingen och ISO får du rätt kunskap i rätt tid, direkt från källan. Med vår kunskap om standarders möjligheter hjälper vi våra kunder att skapa verklig nytta och lönsamhet i sina verksamheter.

**Vill du veta mer om SIS eller hur standarder kan effektivisera din verksamhet är du välkommen in på [www.sis.se](http://www.sis.se) eller ta kontakt med oss på tel 08-555 523 00.**



# Standards make the world go round

*SIS (Swedish Standards Institute) is an independent non-profit organisation with members from both the private and public sectors. We are part of the European and global network that draws up international standards. Standards consist of documented knowledge developed by prominent actors within the industry, business world and society. They promote cross-border trade, they help to make processes and products safer and they streamline your organisation.*

## Take part and have influence

As a member of SIS you will have the possibility to participate in standardization activities on national, European and global level. The membership in SIS will give you the opportunity to influence future standards and gain access to early stage information about developments within your field.

## Get to know the finished work

We offer our customers everything in connection with standards and their application. You can purchase all the publications you need from us - everything from individual standards, technical reports and standard packages through to manuals and online services. Our web service e-nav gives you access to an easy-to-navigate library where all standards that are relevant to your company are available. Standards and manuals are sources of knowledge. We sell them.

## Increase understanding and improve perception

With SIS you can undergo either shared or in-house training in the content and application of standards. Thanks to our proximity to international development and ISO you receive the right knowledge at the right time, direct from the source. With our knowledge about the potential of standards, we assist our customers in creating tangible benefit and profitability in their organisations.

**If you want to know more about SIS, or how standards can streamline your organisation, please visit [www.sis.se](http://www.sis.se) or contact us on phone +46 (0)8-555 523 00**



Den internationella standarden ISO 15:2017 gäller som svensk standard. Detta dokument innehåller den officiella engelska versionen av ISO 15:2017.

The International Standard ISO 15:2017 has the status of a Swedish Standard. This document contains the official version of ISO 15:2017.

© Copyright/Upphovsrätten till denna produkt tillhör SIS, Swedish Standards Institute, Stockholm, Sverige. Användningen av denna produkt regleras av slutanvändarlicensen som återfinns i denna produkt, se standardens sista sidor.

© Copyright SIS, Swedish Standards Institute, Stockholm, Sweden. All rights reserved. The use of this product is governed by the end-user licence for this product. You will find the licence in the end of this document.

*Upplysningar om sakinnehållet i standarden lämnas av SIS, Swedish Standards Institute, telefon 08-555 520 00. Standarder kan beställas hos SIS Förlag AB som även lämnar allmänna upplysningar om svensk och utländsk standard.*

*Information about the content of the standard is available from the Swedish Standards Institute (SIS), telephone +46 8 555 520 00. Standards may be ordered from SIS Förlag AB, who can also provide general information about Swedish and foreign standards.*

Denna standard är framtagen av kommittén för Rullningslager, SIS/TK 105.

Har du synpunkter på innehållet i den här standarden, vill du delta i ett kommande revideringsarbete eller vara med och ta fram andra standarder inom området? Gå in på [www.sis.se](http://www.sis.se) - där hittar du mer information.



# Contents

Page

<b>Foreword</b> .....	<b>iv</b>
<b>Introduction</b> .....	<b>v</b>
<b>1 Scope</b> .....	<b>1</b>
<b>2 Normative references</b> .....	<b>1</b>
<b>3 Terms and definitions</b> .....	<b>1</b>
<b>4 Symbols</b> .....	<b>1</b>
<b>5 Boundary dimensions</b> .....	<b>2</b>
<b>Annex A (informative) Guidelines for the extension of this document for radial bearings</b> .....	<b>22</b>
<b>Bibliography</b> .....	<b>24</b>

## SS-ISO 15:2017 (E)

# Foreword

ISO (the International Organization for Standardization) is a worldwide federation of national standards bodies (ISO member bodies). The work of preparing International Standards is normally carried out through ISO technical committees. Each member body interested in a subject for which a technical committee has been established has the right to be represented on that committee. International organizations, governmental and non-governmental, in liaison with ISO, also take part in the work. ISO collaborates closely with the International Electrotechnical Commission (IEC) on all matters of electrotechnical standardization.

The procedures used to develop this document and those intended for its further maintenance are described in the ISO/IEC Directives, Part 1. In particular, the different approval criteria needed for the different types of ISO documents should be noted. This document was drafted in accordance with the editorial rules of the ISO/IEC Directives, Part 2 (see [www.iso.org/directives](http://www.iso.org/directives)).

Attention is drawn to the possibility that some of the elements of this document may be the subject of patent rights. ISO shall not be held responsible for identifying any or all such patent rights. Details of any patent rights identified during the development of the document will be in the Introduction and/or on the ISO list of patent declarations received (see [www.iso.org/patents](http://www.iso.org/patents)).

Any trade name used in this document is information given for the convenience of users and does not constitute an endorsement.

For an explanation on the voluntary nature of standards, the meaning of ISO specific terms and expressions related to conformity assessment, as well as information about ISO's adherence to the World Trade Organization (WTO) principles in the Technical Barriers to Trade (TBT), see the following URL: [www.iso.org/iso/foreword.html](http://www.iso.org/iso/foreword.html).

This document was prepared by Technical Committee ISO/TC 4, *Rolling bearings*.

This fourth edition cancels and replaces the third edition (ISO 15:2011), which has been technically revised. The tables have been extended to incorporate dimensions of very large bearings.

## **Introduction**

The objective of this document is to restrict the number of radial bearing sizes just enough to ensure economic production, yet provide a sufficient number of sizes to satisfy present and future needs of bearing users.

These needs are comprehensive and varying. Therefore, this document needs to embrace a wide range of numerically determined sizes and proportions and can even be extended according to the guidelines given in [Annex A](#).

Tapered roller bearings, insert bearings and some types of needle roller bearings and instrument precision bearings standardized by ISO do not conform to this document because the dimensions given are not found to be optimal for the bearings in question.





# Rolling bearings — Radial bearings — Boundary dimensions, general plan

## 1 Scope

This document specifies preferred boundary dimensions for radial bearings of the diameter series 7, 8, 9, 0, 1, 2, 3 and 4.

## 2 Normative references

The following documents are referred to in the text in such a way that some or all of their content constitutes requirements of this document. For dated references, only the edition cited applies. For undated references, the latest edition of the referenced document (including any amendments) applies.

ISO 464, *Rolling bearings — Radial bearings with locating snap ring — Dimensions, geometrical product specifications (GPS) and tolerance values*

ISO 5593, *Rolling bearings — Vocabulary*

ISO 12043, *Rolling bearings — Single-row cylindrical roller bearings — Chamfer dimensions for loose rib and non-rib sides*

ISO 12044, *Rolling bearings — Single-row angular contact ball bearings — Chamfer dimensions for outer ring non-thrust side*

## 3 Terms and definitions

For the purposes of this document, the terms and definitions given in ISO 5593 apply.

ISO and IEC maintain terminological databases for use in standardization at the following addresses:

- IEC Electropedia: available at <http://www.electropedia.org/>
- ISO Online browsing platform: available at <http://www.iso.org/obp>

## 4 Symbols

For the purposes of this document, the symbols given in ISO 15241<sup>[3]</sup> and the following apply.

The symbols shown in [Figure 1](#) and given in [Tables 1](#) to [8](#) denote nominal dimensions, unless specified otherwise.

SS-ISO 15:2017 (E)

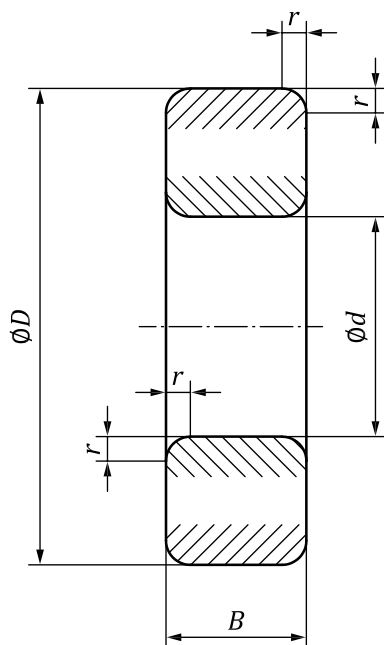

**Key**

- $B$  bearing width
- $D$  bearing outside diameter
- $d$  bearing bore diameter
- $r$  chamfer dimension
- $r_{s \text{ min}}$  smallest permissible single chamfer dimension

**Figure 1 — Radial bearing**

**5 Boundary dimensions**

Boundary dimensions for radial bearings of the diameter series 7, 8, 9, 0, 1, 2, 3 and 4 are given in [Tables 1 to 8](#).

The chamfer dimensions given in [Tables 1 to 8](#) do not always apply to the following:

- the groove side of bearing rings with snap ring groove (these shall be in accordance with ISO 464);
- the loose rib and the non-rib sides of cylindrical roller bearing rings (the exceptions shall be in accordance with ISO 12043);
- the non-thrust side of angular contact bearing outer rings (these shall be in accordance with ISO 12044).

Chamfer dimension,  $r$ , applies at the corners indicated in [Figure 1](#) and is specified with  $r_{s \text{ min}}$  in [Tables 1 to 8](#).

The chamfer dimensions for inner rings of bearings with tapered bore may be smaller than those shown in [Tables 1 to 8](#).

The corresponding largest single chamfer dimensions to the  $r_{s \text{ min}}$  dimensions in [Tables 1 to 8](#) are given in ISO 582[2].

Table 1 — Diameter series 7

Dimensions in millimetres

<i>d</i>	<i>D</i>	Dimension series				<i>r</i> <sub>s min</sub>
		17	27	37	47	
		<i>B</i>				
0,6	2	0,8	—	—	—	0,05
1	2,5	1	—	—	—	0,05
1,5	3	1	—	1,8	—	0,05
2	4	1,2	—	2	—	0,05
2,5	5	1,5	1,8	2,3	—	0,08
3	6	2	2,5	3	—	0,08
4	7	2	2,5	3	—	0,08
5	8	2	2,5	3	—	0,08
6	10	2,5	3	3,5	—	0,1
7	11	2,5	3	3,5	—	0,1
8	12	2,5	—	3,5	—	0,1
9	14	3	—	4,5	—	0,1
10	15	3	—	4,5	—	0,1
12	18	4	—	5	—	0,2
15	21	4	—	5	—	0,2
17	23	4	—	5	—	0,2
20	27	4	—	5	7	0,2
22	30	4	—	5	7	0,2
25	32	4	—	5	7	0,2
28	35	4	—	5	7	0,2
30	37	4	—	5	7	0,2
32	40	4	—	6	8	0,2
35	44	5	—	7	9	0,3
40	50	6	—	8	10	0,3
45	55	6	—	8	10	0,3
50	62	6	—	10	12	0,3
55	68	7	—	10	13	0,3
60	75	7	—	12	15	0,3
65	80	7	—	12	15	0,3
70	85	7	—	12	15	0,3
75	90	7	—	12	15	0,3
80	95	7	—	12	15	0,3
85	105	10	—	15	—	0,6
90	110	10	—	15	—	0,6
95	115	10	—	15	—	0,6
100	120	10	—	15	—	0,6
105	125	10	—	15	—	0,6