

SVENSK STANDARD

SS-EN ISO 5356-1:2015



Fastställt/Approved: 2015-03-22
Publicerad/Published: 2015-04-01
Utgåva/Edition: 2
Språk/Language: engelska/English
ICS: 11.040.10

Anestesi- och ventilationsutrustning – Koniska kopplingar – Del 1: Han- och honkopplingar (ISO 5356-1:2015)

Anaesthetic and respiratory equipment – Conical connectors – Part 1: Cones and sockets (ISO 5356-1:2015)

This preview is downloaded from www.sis.se. Buy the entire standard via <https://www.sis.se/std-8013546>

Standarder får världen att fungera

SIS (Swedish Standards Institute) är en fristående ideell förening med medlemmar från både privat och offentlig sektor. Vi är en del av det europeiska och globala nätverk som utarbetar internationella standarder. Standarder är dokumenterad kunskap utvecklad av framstående aktörer inom industri, näringsliv och samhälle och befrämjar handel över gränser, bidrar till att processer och produkter blir säkrare samt effektiviserar din verksamhet.

Delta och påverka

Som medlem i SIS har du möjlighet att påverka framtida standarder inom ditt område på nationell, europeisk och global nivå. Du får samtidigt tillgång till tidig information om utvecklingen inom din bransch.

Ta del av det färdiga arbetet

Vi erbjuder våra kunder allt som rör standarder och deras tillämpning. Hos oss kan du köpa alla publikationer du behöver – allt från enskilda standarder, tekniska rapporter och standardpaket till handböcker och onlinetjänster. Genom vår webbtjänst e-nav får du tillgång till ett lättnavigerat bibliotek där alla standarder som är aktuella för ditt företag finns tillgängliga. Standarder och handböcker är källor till kunskap. Vi säljer dem.

Utveckla din kompetens och lyckas bättre i ditt arbete

Hos SIS kan du gå öppna eller företagsinterna utbildningar kring innehåll och tillämpning av standarder. Genom vår närhet till den internationella utvecklingen och ISO får du rätt kunskap i rätt tid, direkt från källan. Med vår kunskap om standarders möjligheter hjälper vi våra kunder att skapa verklig nytta och lönsamhet i sina verksamheter.

Vill du veta mer om SIS eller hur standarder kan effektivisera din verksamhet är du välkommen in på www.sis.se eller ta kontakt med oss på tel 08-555 523 00.



Standards make the world go round

SIS (Swedish Standards Institute) is an independent non-profit organisation with members from both the private and public sectors. We are part of the European and global network that draws up international standards. Standards consist of documented knowledge developed by prominent actors within the industry, business world and society. They promote cross-border trade, they help to make processes and products safer and they streamline your organisation.

Take part and have influence

As a member of SIS you will have the possibility to participate in standardization activities on national, European and global level. The membership in SIS will give you the opportunity to influence future standards and gain access to early stage information about developments within your field.

Get to know the finished work

We offer our customers everything in connection with standards and their application. You can purchase all the publications you need from us - everything from individual standards, technical reports and standard packages through to manuals and online services. Our web service e-nav gives you access to an easy-to-navigate library where all standards that are relevant to your company are available. Standards and manuals are sources of knowledge. We sell them.

Increase understanding and improve perception

With SIS you can undergo either shared or in-house training in the content and application of standards. Thanks to our proximity to international development and ISO you receive the right knowledge at the right time, direct from the source. With our knowledge about the potential of standards, we assist our customers in creating tangible benefit and profitability in their organisations.

If you want to know more about SIS, or how standards can streamline your organisation, please visit www.sis.se or contact us on phone +46 (0)8-555 523 00



Europastandarden EN ISO 5356-1:2015 gäller som svensk standard. Detta dokument innehåller den officiella engelska versionen av EN ISO 5356-1:2015.

Denna standard ersätter SS-EN ISO 5356-1:2004, utgåva 1.

The European Standard EN ISO 5356-1:2015 has the status of a Swedish Standard. This document contains the official English version of EN ISO 5356-1:2015.

This standard supersedes the Swedish Standard SS-EN ISO 5356-1:2004, edition 1.

**Förhållandet till övriga delar under samma huvudtitel - Utdrag ur Förord i ISO 5356-1:2015/
Relations to other parts under the same general title - Extract from the Foreword of ISO 5356-1:2015**

ISO 5356 consists of the following parts, under the general title *Anaesthetic and respiratory equipment — Conical connectors*:

- Part 1: *Cones and sockets*
- Part 2: *Screw-threaded weight-bearing connectors*

© Copyright/Upphovsrätten till denna produkt tillhör SIS, Swedish Standards Institute, Stockholm, Sverige. Användningen av denna produkt regleras av slutanvändarlicensen som återfinns i denna produkt, se standardens sista sidor.

© Copyright SIS, Swedish Standards Institute, Stockholm, Sweden. All rights reserved. The use of this product is governed by the end-user licence for this product. You will find the licence in the end of this document.

Upplysningar om sakinnehållet i standarden lämnas av SIS, Swedish Standards Institute, telefon 08-555 520 00. Standarder kan beställas hos SIS Förlag AB som även lämnar allmänna upplysningar om svensk och utländsk standard.

Information about the content of the standard is available from the Swedish Standards Institute (SIS), telephone +46 8 555 520 00. Standards may be ordered from SIS Förlag AB, who can also provide general information about Swedish and foreign standards.

Denna standard är framtagen av kommittén för Anestesi- och respiratorutrustning, SIS/TK 329.

Har du synpunkter på innehållet i den här standarden, vill du delta i ett kommande revideringsarbete eller vara med och ta fram andra standarder inom området? Gå in på www.sis.se - där hittar du mer information.

EUROPEAN STANDARD

EN ISO 5356-1

NORME EUROPÉENNE

EUROPÄISCHE NORM

March 2015

ICS 11.040.10

Supersedes EN ISO 5356-1:2004

English Version

Anaesthetic and respiratory equipment - Conical connectors - Part 1: Cones and sockets (ISO 5356-1:2015)

Matériel d'anesthésie et de réanimation respiratoire -
Raccords coniques - Partie 1: Raccords mâles et femelles
(ISO 5356-1:2015)

Anästhesie- und Beatmungsgeräte - Konische Konnektoren
- Teil 1: Männliche und weibliche Konen (ISO 5356-1:2015)

This European Standard was approved by CEN on 10 January 2015.

CEN members are bound to comply with the CEN/CENELEC Internal Regulations which stipulate the conditions for giving this European Standard the status of a national standard without any alteration. Up-to-date lists and bibliographical references concerning such national standards may be obtained on application to the CEN-CENELEC Management Centre or to any CEN member.

This European Standard exists in three official versions (English, French, German). A version in any other language made by translation under the responsibility of a CEN member into its own language and notified to the CEN-CENELEC Management Centre has the same status as the official versions.

CEN members are the national standards bodies of Austria, Belgium, Bulgaria, Croatia, Cyprus, Czech Republic, Denmark, Estonia, Finland, Former Yugoslav Republic of Macedonia, France, Germany, Greece, Hungary, Iceland, Ireland, Italy, Latvia, Lithuania, Luxembourg, Malta, Netherlands, Norway, Poland, Portugal, Romania, Slovakia, Slovenia, Spain, Sweden, Switzerland, Turkey and United Kingdom.



EUROPEAN COMMITTEE FOR STANDARDIZATION
COMITÉ EUROPÉEN DE NORMALISATION
EUROPÄISCHES KOMITEE FÜR NORMUNG

CEN-CENELEC Management Centre: Avenue Marnix 17, B-1000 Brussels

Contents		Page
Foreword		iv
Introduction		v
1 Scope		1
2 Normative references		1
3 Dimensional requirements		1
3.1 General requirements		1
3.2 Additional requirements		3
4 22 mm latching sockets		4
Annex A (normative) Plug and ring test gauges for cones and sockets made of materials other than metal		5
Annex B (normative) Test for security of engagement of 22 mm latching sockets to cones		7
Annex C (normative) Test for leakage from 22 mm latching sockets		8
Annex D (normative) Drop procedure for 22 mm latching sockets		9
Annex E (informative) Plug and ring test gauges for cones and sockets made of metal		10
Annex F (informative) Suggested apparatus and methods for testing the security of engagement of 22 mm latching sockets		12
Bibliography		17

Foreword

This document (EN ISO 5356-1:2015) has been prepared by Technical Committee ISO/TC 121 "Anaesthetic and respiratory equipment" in collaboration with Technical Committee CEN/TC 215 "Respiratory and anaesthetic equipment" the secretariat of which is held by BSI.

This European Standard shall be given the status of a national standard, either by publication of an identical text or by endorsement, at the latest by September 2015, and conflicting national standards shall be withdrawn at the latest by September 2015.

Attention is drawn to the possibility that some of the elements of this document may be the subject of patent rights. CEN [and/or CENELEC] shall not be held responsible for identifying any or all such patent rights.

This document supersedes EN ISO 5356-1:2004.

According to the CEN-CENELEC Internal Regulations, the national standards organizations of the following countries are bound to implement this European Standard: Austria, Belgium, Bulgaria, Croatia, Cyprus, Czech Republic, Denmark, Estonia, Finland, Former Yugoslav Republic of Macedonia, France, Germany, Greece, Hungary, Iceland, Ireland, Italy, Latvia, Lithuania, Luxembourg, Malta, Netherlands, Norway, Poland, Portugal, Romania, Slovakia, Slovenia, Spain, Sweden, Switzerland, Turkey and the United Kingdom.

Endorsement notice

The text of ISO 5356-1:2015 has been approved by CEN as EN ISO 5356-1:2015 without any modification.

Introduction

In clinical practice, several breathing attachments used in anaesthetic and respiratory equipment may have to be joined together to provide a suitable breathing system. Items of medical equipment, such as a humidifier or a spirometer, are often incorporated into the breathing system which might also be connected to an anaesthetic gas scavenging system. Connections for these purposes are usually cone and socket joints, and a lack of standardization of these connections has given rise to problems of interchangeability when connecting equipment made by different manufacturers. This part of ISO 5356 specifies the requirements and dimensions for cones and sockets used in anaesthetic and respiratory equipment.

An important consideration is that conical connections need to be secure but nevertheless disconnectable by the operator. The use of cones and sockets meeting the requirements of this part of ISO 5356 will not necessarily prevent them being disconnected accidentally. To minimize the risk of 22 mm connectors being accidentally disconnected, latching sockets can be used.

[Annex A](#) includes a figure and a table detailing plug and ring test gauges that are used to check cones and sockets made of materials other than metal. [Annex B](#), [Annex C](#), and [Annex D](#) provide test methods for latching sockets, [Annex E](#) includes a figure and table detailing plug and ring test gauges that can be used to check metal cones and sockets, and [Annex F](#) contains recommendations for testing the security of latching sockets.

[Figure 1](#), detailing the dimensions and tolerances of cones and sockets, has been prepared in accordance with ISO 3040.

In this document, the following print types are used:

- requirements, compliance with which can be verified, and definitions: roman type;
- notes and examples: smaller roman type;
- test methods: *italic type*.

Anaesthetic and respiratory equipment — Conical connectors —

Part 1: Cones and sockets

1 Scope

This part of ISO 5356 specifies dimensional and gauging requirements for cones and sockets intended for connecting anaesthetic and respiratory equipment, e.g. in breathing systems, anaesthetic gas scavenging systems, and vaporizers. The cones and sockets are therefore not regarded as devices in their own right.

This part of ISO 5356 gives requirements for the following cones and sockets:

- 8,5 mm and 11,5 mm sizes intended for use in neonatal and paediatric breathing systems;
- 15 mm and 22 mm sizes intended for general use in breathing systems;
- 22 mm latching sockets (including performance requirements);
- 23 mm size intended for use with vaporizers, but not for use in breathing systems;
- 30 mm size intended for the connection of a breathing system to an anaesthetic gas scavenging system.

This part of ISO 5356 does not specify the medical devices and accessories on which these cones and sockets are to be provided.

Requirements for the application of cones and sockets are not included in this part of ISO 5356, but are or will be given in the relevant International Standards for specific medical devices and accessories.

NOTE Requirements for screw-threaded weight-bearing connectors are specified in ISO 5356-2.

2 Normative references

The following documents, in whole or in part, are normatively referenced in this document and are indispensable for its application. For dated references, only the edition cited applies. For undated references, the latest edition of the referenced document (including any amendments) applies.

ISO 5367:2014, *Anaesthetic and respiratory equipment — Breathing sets and connectors*

3 Dimensional requirements

3.1 General requirements

3.1.1 Cones and sockets made of metal shall comply with [Figure 1](#) and the dimensions given in [Table 1](#) as appropriate.

Check compliance by functional testing.

NOTE [Annex E](#) includes a figure and table detailing plug and ring test gauges that can be used to check metal cones and sockets.

3.1.2 Cones and sockets made of non-metallic materials shall comply with [Figure 1](#) and the dimensions given in [Table 1](#) except that the dimensions A and B and ratio F may vary from those given in [Table 1](#).

Check compliance by engaging the cone or socket in the appropriate plug or ring test gauge according to [Figure A.1](#) and [Table A.1](#), by applying an axial force of $(35 \pm 3,5)$ N for 8,5 mm, 11,5 mm, and 15 mm cones or sockets and (50 ± 5) N for 22 mm and 30 mm cones or sockets while simultaneously rotating the cone or socket $(20 \pm 5)^\circ$. Its leading edge shall lie between the minimum and maximum diameter steps of the gauge. The cones or sockets and gauges shall be maintained at a temperature of (20 ± 3) °C during the test.

NOTE Because cones or sockets made from plastics materials (for example polyamide, polyacetal, polycarbonate, polysulfone) can vary greatly in their physical characteristics, it is not considered practicable to specify dimensions A , B , and ratio F ; for this reason, gauging requirements have been included. It is also considered impracticable to generalize on matters such as cold flow and thermal instability, as well as possible changes in physical characteristics, contact with solvents, etc.

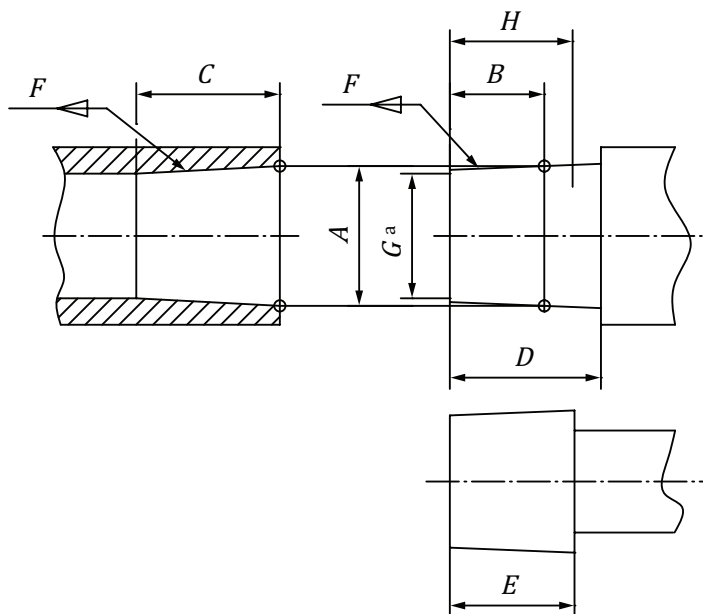

^a For the 8,5 mm cone and the 30 mm cone, dimension G over the minimum length, H , as specified in [Table 1](#).

NOTE The radius on the entrance to the socket and on the leading edge of the cone is not intended to be less than 0,5 mm and not more than 0,8 mm.

Figure 1 — Interconnecting details of cones and sockets

Table 1 — Dimensions of cones and sockets (see Figure 1)

Dimensions in millimetres

Connector size	A	B	Taper length C	Clearance to shoulder (if present) D	Length to taper E	Taper ratio F	Minimum internal diameter of cone G	Minimum length of internal diameter of the cone (G) H
8,5	8,45 ± 0,04	6	≥6,4	≥8,9	≥8	1:19	6,25	6,0
11,5	11,50 ± 0,04	10	≥13,5	≥16	≥15	1:40	a	a
15	15,47 ± 0,04	10	≥16	≥16	≥14,5	1:40	a	a
22	22,37 ± 0,04	15	≥21	See Figure 3	See Figure 3	1:40	a	a
23	23,175 ± 0,02	13	≥18	≥18	≥15	1:36	a	a
30	30,9 ± 0,05	14	≥18	≥18	≥14	1:20	27,0	12,0

a Not specified.

3.2 Additional requirements

3.2.1 22 mm cones designed to connect to a breathing tube complying with ISO 5367:2014, 5.3.2.2, or a latching socket (see Clause 4) shall incorporate a recess, the dimensions of which are given in Figure 2.

Check compliance by functional testing.

Dimensions in millimetres

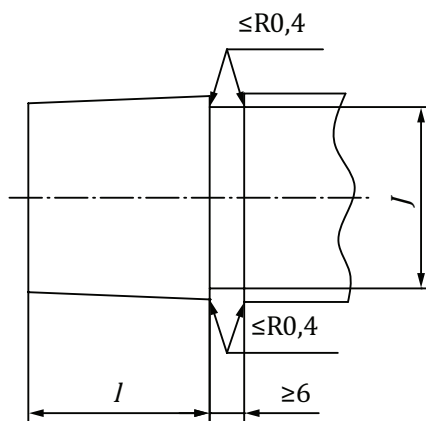

Key

l taper length: $19,5^{+0,5}_0$

J diameter of recess: $20^{+0,5}_0$

Figure 2 — Details of recess for 22 mm cones

3.2.2 22 mm cones, designed to connect to a face mask shall incorporate a means to prevent over insertion (e.g. shoulder) and comply with the dimensions given in Figure 3.

Check compliance by functional testing.