

SVENSK STANDARD

SS-ISO 104:2021

Rolling bearings – Thrust bearings – Boundary dimensions,
general plan (ISO 104:2015, IDT)

Rolling bearings – Thrust bearings – Boundary dimensions,
general plan (ISO 104:2015, IDT)



sis Svenska
Institutet för
Standarder

Language: engelska/English

Edition: 1

This preview is downloaded from www.sis.se. Buy the entire
standard via <https://www.sis.se/std-80026990>

Den här standarden kan hjälpa dig att effektivisera och kvalitetssäkra ditt arbete. SIS har fler tjänster att erbjuda dig för att underlätta tillämpningen av standarder i din verksamhet.

SIS Abonnemang

Snabb och enkel åtkomst till gällande standard med SIS Abonnemang, en prenumerationstjänst genom vilken din organisation får tillgång till all världens standarder, senaste uppdateringarna och där hela din organisation kan ta del av innehållet i prenumerationen.

Utbildning, event och publikationer

Vi erbjuder även utbildningar, rådgivning och event kring våra mest sålda standarder och frågor kopplade till utveckling av standarder. Vi ger också ut handböcker som underlättar ditt arbete med att använda en specifik standard.

Vill du delta i ett standardiseringsprojekt?

Genom att delta som expert i någon av SIS 300 tekniska kommittéer inom CEN (europeisk standardisering) och/eller ISO (internationell standardisering) har du möjlighet att påverka standardiseringsarbetet i frågor som är viktiga för din organisation. Välkommen att kontakta SIS för att få veta mer!

Kontakt

Skriv till kundservice@sis.se, besök [sis.se](https://www.sis.se) eller ring 08 - 555 523 10

© Copyright/Upphovsrätten till denna produkt tillhör Svenska institutet för standarder, Stockholm, Sverige. Upphovsrätten och användningen av denna produkt regleras i slutanvändarlicensen som återfinns på [sis.se/slutanvandarlicens](https://www.sis.se/slutanvandarlicens) och som du automatiskt blir bunden av när du använder produkten. För ordlista och förkortningar se [sis.se/ordlista](https://www.sis.se/ordlista).

© Copyright Svenska institutet för standarder, Stockholm, Sweden. All rights reserved. The copyright and use of this product is governed by the end-user licence agreement which you automatically will be bound to when using the product. You will find the licence at [sis.se/enduserlicenseagreement](https://www.sis.se/enduserlicenseagreement).

Upplysningar om sakinnehållet i standarden lämnas av Svenska institutet för standarder, telefon 08 - 555 520 00. Standarder kan beställas hos SIS som även lämnar allmänna upplysningar om svensk och utländsk standard.

Standarden är framtagen av kommittén för Rullningslager, SIS/TK 105.

Har du synpunkter på innehållet i den här standarden, vill du delta i ett kommande revideringsarbete eller vara med och ta fram andra standarder inom området? Gå in på www.sis.se - där hittar du mer information.

Den internationella standarden ISO 104:2015 gäller som svensk standard. Detta dokument innehåller den officiella engelska versionen av ISO 104:2015.

The International Standard ISO 104:2015 has the status of a Swedish Standard. This document contains the official English version of ISO 104:2015.

LÄSANVISNINGAR FÖR STANDARDER

I dessa anvisningar behandlas huvudprinciperna för hur regler och yttre begränsningar anges i standardiseringsprodukter.

Krav

Ett krav är ett uttryck i ett dokumentets innehåll som anger objektivet verifierbara kriterier som ska uppfyllas och från vilka ingen avvikelse tillåts om efterlevnad av dokumentet ska kunna åberopas. Krav uttrycks med hjälpverbet ska (eller ska inte för förbud).

Rekommendation

En rekommendation är ett uttryck i ett dokumentets innehåll som anger en valmöjlighet eller ett tillvägagångssätt som bedöms vara särskilt lämpligt utan att nödvändigtvis nämna eller utesluta andra. Rekommendationer uttrycks med hjälpverbet bör (eller bör inte för avrådanden).

Instruktion

Instruktioner anges i imperativ form och används för att ange hur något görs eller utförs. De kan underordnas en annan regel, såsom ett krav eller en rekommendation. De kan även användas självständigt, och är då att betrakta som krav.

Förklaring

En förklaring är ett uttryck i ett dokumentets innehåll som förmedlar information. En förklaring kan uttrycka tillåtelse, möjlighet eller förmåga. Tillåtelse uttrycks med hjälpverbet får (eller motsatsen behöver inte). Möjlighet och förmåga uttrycks med hjälpverbet kan (eller motsatsen kan inte).

READING INSTRUCTIONS FOR STANDARDS

These instructions cover the main principles for the use of provisions and external constraints in standardization deliverables.

Requirement

A requirement is an expression, in the content of a document, that conveys objectively verifiable criteria to be fulfilled, and from which no deviation is permitted if conformance with the document is to be claimed. Requirements are expressed by the auxiliary shall (or shall not for prohibition).

Recommendation

A recommendation is an expression, in the content of a document, that conveys a suggested possible choice or course of action deemed to be particularly suitable, without necessarily mentioning or excluding others. Recommendations are expressed by the auxiliary should (or should not for dissuasion).

Instruction

An instruction is expressed in the imperative mood and is used in order to convey an action to be performed. It can be subordinated to another provision, such as a requirement or a recommendation. It can also be used independently and is then to be regarded as a requirement.

Statement

A statement is an expression, in the content of a document, that conveys information. A statement can express permission, possibility or capability. Permission is expressed by the auxiliary may (its opposite being need not). Possibility and capability are expressed by the auxiliary can (its opposite being cannot).

Contents

Page

Foreword	vi
1 Scope	1
2 Normative references	1
3 Terms and definitions	1
4 Symbols	1
5 Boundary dimensions	3
5.1 General	3
5.2 Single-direction thrust bearings with flat back faces.....	3
5.3 Double-direction thrust bearings with flat back faces	16
Annex A (informative) Guidelines for the extension of this International Standard for single-direction thrust bearings	19
Bibliography	21

Foreword

ISO (the International Organization for Standardization) is a worldwide federation of national standards bodies (ISO member bodies). The work of preparing International Standards is normally carried out through ISO technical committees. Each member body interested in a subject for which a technical committee has been established has the right to be represented on that committee. International organizations, governmental and non-governmental, in liaison with ISO, also take part in the work. ISO collaborates closely with the International Electrotechnical Commission (IEC) on all matters of electrotechnical standardization.

The procedures used to develop this document and those intended for its further maintenance are described in the ISO/IEC Directives, Part 1. In particular the different approval criteria needed for the different types of ISO documents should be noted. This document was drafted in accordance with the editorial rules of the ISO/IEC Directives, Part 2 (see www.iso.org/directives).

Attention is drawn to the possibility that some of the elements of this document may be the subject of patent rights. ISO shall not be held responsible for identifying any or all such patent rights. Details of any patent rights identified during the development of the document will be in the Introduction and/or on the ISO list of patent declarations received (see www.iso.org/patents).

Any trade name used in this document is information given for the convenience of users and does not constitute an endorsement.

For an explanation on the meaning of ISO specific terms and expressions related to conformity assessment, as well as information about ISO's adherence to the WTO principles in the Technical Barriers to Trade (TBT) see the following URL: [Foreword - Supplementary information](#)

The committee responsible for this document is ISO/TC 4, *Rolling bearings*.

This fourth edition cancels and replaces the third edition (ISO 104:2002), which has been technically revised with changes that are editorial and concern mainly on terminology and format.

Rolling bearings — Thrust bearings — Boundary dimensions, general plan

1 Scope

This International Standard specifies preferred boundary dimensions for single-direction and double-direction thrust bearings with flat back faces.

In addition, it gives the minimum bore diameters of housing washers and maximum outside diameters of shaft washers of bearings in dimension series 11, 12, 13, 14, 22, 23 and 24.

Guidelines for the extension of this International Standard for single-direction thrust bearings are given in [Annex A](#).

NOTE Boundary dimensions for aligning thrust bearings (none flat back faces) and aligning seat washers are given in ISO 20516.^[2]

2 Normative references

The following documents, in whole or in part, are normatively referenced in this document and are indispensable for its application. For dated references, only the edition cited applies. For undated references, the latest edition of the referenced document (including any amendments) applies.

ISO 582, *Rolling bearings — Chamfer dimensions — Maximum values*

ISO 5593, *Rolling bearings — Vocabulary*

ISO 15241, *Rolling bearings — Symbols for physical quantities*

3 Terms and definitions

For the purposes of this document, the terms and definitions given in ISO 5593 and the following apply.

3.1

single-direction thrust bearing with flat back faces

thrust rolling bearing with flat back faces intended to support axial load in one direction only

3.2

double-direction thrust bearing with flat back faces

thrust rolling bearing with flat back faces intended to support axial load in both directions

3.3

central shaft washer

central washer which is intended to be mounted on a shaft

[SOURCE: ISO 20516:2007, 3.5]

4 Symbols

For the purposes of this International Standard, the symbols given in ISO 15241 and the following apply.

The symbols shown in [Figures 1](#) and [2](#) and the values given in [Tables 1](#) to [9](#) denote nominal dimensions, unless specified otherwise.

SS-ISO 104:2021 (E)

- B height of central shaft washer
- D outside diameter of housing washer
- D_1 bore diameter of housing washer
- $D_{1s\ min}$ smallest single bore diameter of housing washer
- d bore diameter of shaft washer, single-direction thrust bearing with flat back faces
- d_1 outside diameter of shaft washer, single-direction thrust bearing with flat back faces
- $d_{1s\ max}$ largest single outside diameter of shaft washer
- d_2 bore diameter of central shaft washer, double-direction thrust bearing with flat back faces
- d_3 outside diameter of central shaft washer, double-direction thrust bearing with flat back faces
- $d_{3s\ max}$ largest single outside diameter of central shaft washer
- r back face chamfer dimension of shaft washer and housing washer
- $r_{s\ min}$ smallest single back face chamfer dimension of shaft washer and housing washer
- r_1 face chamfer dimension of central shaft washer
- $r_{1s\ min}$ smallest single face chamfer dimension of central shaft washer
- T bearing height, single-direction thrust bearing with flat back faces
- T_1 bearing height, double-direction thrust bearing with flat back faces

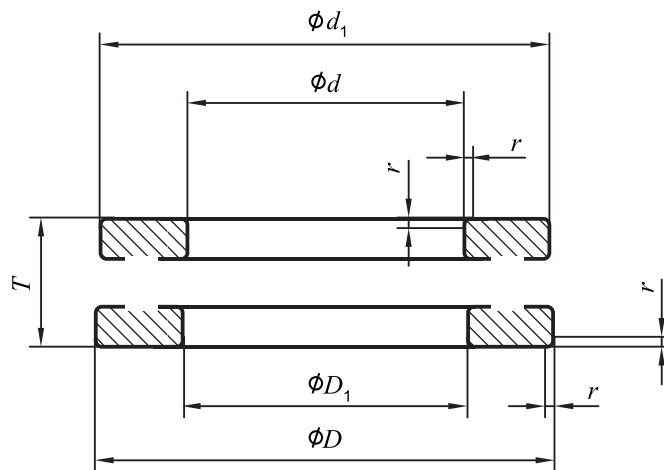

Figure 1 — Single-direction thrust bearing with flat back faces

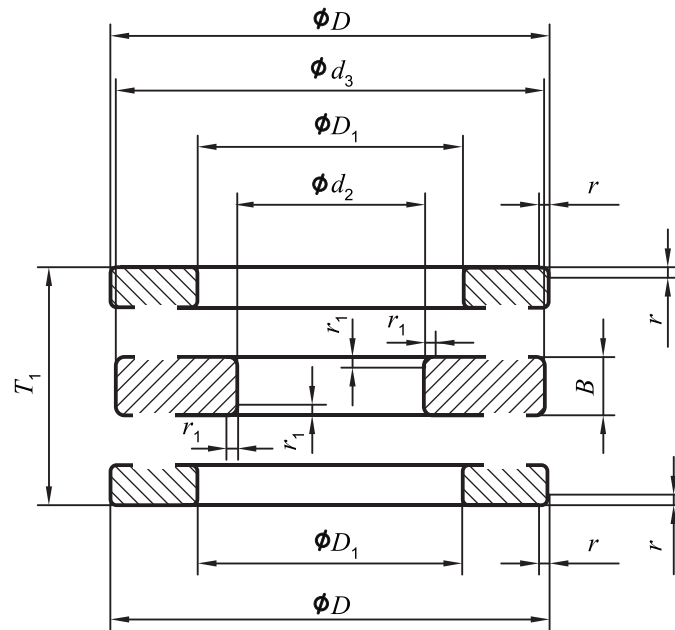

Figure 2 — Double-direction thrust bearing with flat back faces

5 Boundary dimensions

5.1 General

The corresponding largest single chamfer dimensions to the $r_{s \min}$ dimensions in [Tables 1 to 9](#) and $r_{1s \min}$ dimensions in [Tables 7 to 9](#) are given in ISO 582.

Chamfer dimensions r and r_1 apply only at the corners indicated in [Figures 1 and 2](#). No dimensions are given for other corners; however, they should not be sharp.

5.2 Single-direction thrust bearings with flat back faces

Dimensions for single-direction thrust bearings with flat back faces are given in [Tables 1 to 6](#).

Table 1 — Single-direction thrust bearings — Diameter series 0

Dimensions in millimetres

d	D	$r_{s \min}$	Dimension series		
			70	90	10
			T		
4	12	0,3	4	—	6
6	16	0,3	5	—	7
8	18	0,3	5	—	7
10	20	0,3	5	—	7
12	22	0,3	5	—	7
15	26	0,3	5	—	7
17	28	0,3	5	—	7
20	32	0,3	6	—	8
25	37	0,3	6	—	8

Table 1 (continued)

<i>d</i>	<i>D</i>	<i>r_s min</i>	Dimension series		
			70	90	10
			<i>T</i>		
30	42	0,3	6	—	8
35	47	0,3	6	—	8
40	52	0,3	6	—	9
45	60	0,3	7	—	10
50	65	0,3	7	—	10
55	70	0,3	7	—	10
60	75	0,3	7	—	10
65	80	0,3	7	—	10
70	85	0,3	7	—	10
75	90	0,3	7	—	10
80	95	0,3	7	—	10
85	100	0,3	7	—	10
90	105	0,3	7	—	10
100	120	0,6	9	—	14
110	130	0,6	9	—	14
120	140	0,6	9	—	14
130	150	0,6	9	—	14
140	160	0,6	9	—	14
150	170	0,6	9	—	14
160	180	0,6	9	—	14
170	190	0,6	9	—	14
180	200	0,6	9	—	14
190	215	1	11	—	17
200	225	1	11	—	17
220	250	1	14	—	22
240	270	1	14	—	22
260	290	1	14	—	22
280	310	1	14	—	22
300	340	1	18	24	30
320	360	1	18	24	30
340	380	1	18	24	30
360	400	1	18	24	30
380	420	1	18	24	30
400	440	1	18	24	30
420	460	1	18	24	30

Table 1 (continued)

<i>d</i>	<i>D</i>	<i>r_s min</i>	Dimension series		
			70	90	10
			<i>T</i>		
440	480	1	18	24	30
460	500	1	18	24	30
480	520	1	18	24	30
500	540	1	18	24	30
530	580	1,1	23	30	38
560	610	1,1	23	30	38
600	650	1,1	23	30	38
630	680	1,1	23	30	38
670	730	1,5	27	36	45
710	780	1,5	32	42	53
750	820	1,5	32	42	53
800	870	1,5	32	42	53
850	920	1,5	32	42	53
900	980	2	36	48	63
950	1 030	2	36	48	63
1 000	1 090	2,1	41	54	70
1 060	1 150	2,1	41	54	70
1 120	1 220	2,1	45	60	80
1 180	1 280	2,1	45	60	80
1 250	1 360	3	50	67	85
1 320	1 440	3	—	—	95
1 400	1 520	3	—	—	95
1 500	1 630	4	—	—	105
1 600	1 730	4	—	—	105
1 700	1 840	4	—	—	112
1 800	1 950	4	—	—	120
1 900	2 060	5	—	—	130
2 000	2 160	5	—	—	130
2 120	2 300	5	—	—	140
2 240	2 430	5	—	—	150
2 360	2 550	5	—	—	150
2 500	2 700	5	—	—	160