

SVENSK STANDARD

SS-EN 16922:2017+A1:2019



Fastställt/Approved: 2019-07-02
Utgåva/Edition: 1
Språk/Language: engelska/English
ICS: 14.540;45.020;45.060.20

Järnvägar – Service – Toalettömningsystem

Railway applications – Ground based services – Vehicle waste water discharge equipment

This preview is downloaded from www.sis.se. Buy the entire standard via <https://www.sis.se/std-80012684>

Standarder får världen att fungera

SIS (Swedish Standards Institute) är en fristående ideell förening med medlemmar från både privat och offentlig sektor. Vi är en del av det europeiska och globala nätverk som utarbetar internationella standarder. Standarder är dokumenterad kunskap utvecklad av framstående aktörer inom industri, näringsliv och samhälle och befrämjar handel över gränser, bidrar till att processer och produkter blir säkrare samt effektiviserar din verksamhet.

Delta och påverka

Som medlem i SIS har du möjlighet att påverka framtida standarder inom ditt område på nationell, europeisk och global nivå. Du får samtidigt tillgång till tidig information om utvecklingen inom din bransch.

Ta del av det färdiga arbetet

Vi erbjuder våra kunder allt som rör standarder och deras tillämpning. Hos oss kan du köpa alla publikationer du behöver – allt från enskilda standarder, tekniska rapporter och standardpaket till handböcker och onlinetjänster. Genom vår webbtjänst e-nav får du tillgång till ett lättnavigerat bibliotek där alla standarder som är aktuella för ditt företag finns tillgängliga. Standarder och handböcker är källor till kunskap. Vi säljer dem.

Utveckla din kompetens och lyckas bättre i ditt arbete

Hos SIS kan du gå öppna eller företagsinterna utbildningar kring innehåll och tillämpning av standarder. Genom vår närhet till den internationella utvecklingen och ISO får du rätt kunskap i rätt tid, direkt från källan. Med vår kunskap om standarders möjligheter hjälper vi våra kunder att skapa verklig nytta och lönsamhet i sina verksamheter.

Vill du veta mer om SIS eller hur standarder kan effektivisera din verksamhet är du välkommen in på www.sis.se eller ta kontakt med oss på tel 08-555 523 00.

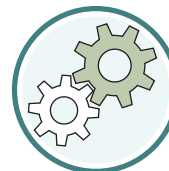

Standards make the world go round

SIS (Swedish Standards Institute) is an independent non-profit organisation with members from both the private and public sectors. We are part of the European and global network that draws up international standards. Standards consist of documented knowledge developed by prominent actors within the industry, business world and society. They promote cross-border trade, they help to make processes and products safer and they streamline your organisation.

Take part and have influence

As a member of SIS you will have the possibility to participate in standardization activities on national, European and global level. The membership in SIS will give you the opportunity to influence future standards and gain access to early stage information about developments within your field.

Get to know the finished work

We offer our customers everything in connection with standards and their application. You can purchase all the publications you need from us - everything from individual standards, technical reports and standard packages through to manuals and online services. Our web service e-nav gives you access to an easy-to-navigate library where all standards that are relevant to your company are available. Standards and manuals are sources of knowledge. We sell them.

Increase understanding and improve perception

With SIS you can undergo either shared or in-house training in the content and application of standards. Thanks to our proximity to international development and ISO you receive the right knowledge at the right time, direct from the source. With our knowledge about the potential of standards, we assist our customers in creating tangible benefit and profitability in their organisations.

If you want to know more about SIS, or how standards can streamline your organisation, please visit www.sis.se or contact us on phone +46 (0)8-555 523 00



Europastandarden EN 16922:2017+A1 gäller som svensk standard. Detta dokument innehåller den officiella engelska versionen av EN 16922:2017+A1.

Denna standard ersätter SS-EN 16922:2017, utgåva 1.

The European Standard EN 16922:2017+A1 has the status of a Swedish Standard. This document contains the official version of EN 16922:2017+A1.

This standard supersedes the SS-EN 16922:2017, edition 1.

© Copyright/Upphovsrätten till denna produkt tillhör SIS, Swedish Standards Institute, Stockholm, Sverige. Användningen av denna produkt regleras av slutanvändarlicensen som återfinns i denna produkt, se standardens sista sidor.

© Copyright SIS, Swedish Standards Institute, Stockholm, Sweden. All rights reserved. The use of this product is governed by the end-user licence for this product. You will find the licence in the end of this document.

Upplysningar om sakinnehållet i standarden lämnas av SIS, Swedish Standards Institute, telefon 08-555 520 00. Standarder kan beställas hos SIS som även lämnar allmänna upplysningar om svensk och utländsk standard.

Information about the content of the standard is available from the Swedish Standards Institute (SIS), telephone +46 8 555 520 00. Standards may be ordered from SIS, who can also provide general information about Swedish and foreign standards.

Denna standard är framtagen av kommittén för Järnvägar, SIS/TK 254.

Har du synpunkter på innehållet i den här standarden, vill du delta i ett kommande revideringsarbete eller vara med och ta fram andra standarder inom området? Gå in på www.sis.se - där hittar du mer information.

EUROPEAN STANDARD

EN 16922:2017+A1

NORME EUROPÉENNE

EUROPÄISCHE NORM

June 2019

ICS 45.060.20

English Version

Railway applications - Ground based services - Vehicle waste water discharge equipment

Applications ferroviaires - Services au sol - Equipement
de vidange des eaux usées des véhicules

Bahnanwendungen - Versorgungsdienste -
Fahrzeugabwasserentsorgungseinrichtungen

This European Standard was approved by CEN on 28 August 2017 and includes Amendment 1 approved by CEN on 16 April 2019.

CEN members are bound to comply with the CEN/CENELEC Internal Regulations which stipulate the conditions for giving this European Standard the status of a national standard without any alteration. Up-to-date lists and bibliographical references concerning such national standards may be obtained on application to the CEN-CENELEC Management Centre or to any CEN member.

This European Standard exists in three official versions (English, French, German). A version in any other language made by translation under the responsibility of a CEN member into its own language and notified to the CEN-CENELEC Management Centre has the same status as the official versions.

CEN members are the national standards bodies of Austria, Belgium, Bulgaria, Croatia, Cyprus, Czech Republic, Denmark, Estonia, Finland, France, Germany, Greece, Hungary, Iceland, Ireland, Italy, Latvia, Lithuania, Luxembourg, Malta, Netherlands, Norway, Poland, Portugal, Republic of North Macedonia, Romania, Serbia, Slovakia, Slovenia, Spain, Sweden, Switzerland, Turkey and United Kingdom.



EUROPEAN COMMITTEE FOR STANDARDIZATION
COMITÉ EUROPÉEN DE NORMALISATION
EUROPÄISCHES KOMITEE FÜR NORMUNG

CEN-CENELEC Management Centre: Rue de la Science 23, B-1040 Brussels

SS-EN 16922:2017+A1:2019 (E)

Contents	Page
European foreword.....	3
1 Scope	4
2 Normative references	4
3 Terms and definitions	4
4 General	5
4.1 Description of vacuum	5
4.2 Description of controlled emission toilet systems	5
5 Requirements	5
5.1 General requirements	5
5.2 Vehicle requirements	6
5.2.1 Connections	6
5.2.2 System design	10
5.2.3 Temperature of operation	10
5.2.4 Pipework	11
5.2.5 Retention tank	12
5.2.6 Venting system	14
5.2.7 Sink waste	14
5.2.8 Test for leakage	14
5.3 Infrastructure requirements	14
5.3.1 General	14
5.3.2 System design	14
5.3.3 Connection	15
5.3.4 Flushing	15
5.3.5 Breakaway coupling	15
5.3.6 Pipework	15
5.3.7 Chemical storage	15
5.4 Information and instruction	15
5.4.1 For railway vehicles	15
5.4.2 For fixed installations (this includes mobile ground based installations)	16
Annex A (informative) Generic types of toilet retention systems	17
Annex ZA (informative) Relationship between this European Standard and the Essential Requirements of EU Directive 2008/57/EC aimed to be covered	22
Bibliography	24

European foreword

This document (EN 16922:2017+A1:2019) has been prepared by Technical Committee CEN/TC 256 “Railway applications”, the secretariat of which is held by DIN.

This European Standard shall be given the status of a national standard, either by publication of an identical text or by endorsement, at the latest by December 2019, and conflicting national standards shall be withdrawn at the latest by December 2019.

Attention is drawn to the possibility that some of the elements of this document may be the subject of patent rights. CEN shall not be held responsible for identifying any or all such patent rights.

This document includes Amendment 1 approved by CEN on 16 April 2019.

This document supersedes A1 EN 16922:2017 A1.

The start and finish of text introduced or altered by amendment is indicated in the text by tags A1 A1.

This document has been prepared under a mandate given to CEN by the European Commission and the European Free Trade Association, and supports essential requirements of EU Directive 2008/57/EC.

For relationship with EU Directive 2008/57/EC, see informative Annex ZA, which is an integral part of this document.

According to the CEN-CENELEC Internal Regulations, the national standards organizations of the following countries are bound to implement this European Standard: Austria, Belgium, Bulgaria, Croatia, Cyprus, Czech Republic, Denmark, Estonia, Finland, France, Germany, Greece, Hungary, Iceland, Ireland, Italy, Latvia, Lithuania, Luxembourg, Malta, Netherlands, Norway, Poland, Portugal, Republic of North Macedonia, Romania, Serbia, Slovakia, Slovenia, Spain, Sweden, Switzerland, Turkey and the United Kingdom.

SS-EN 16922:2017+A1:2019 (E)

1 Scope

This European Standard specifies the interface requirements for controlled emission toilet equipment on railway vehicles and the infrastructure, including catering area sink waste retention tanks. Vehicle and infrastructure specific requirements are also given.

The European Standard includes fixed and portable infrastructure equipment used to empty retention tanks, but excludes equipment fitted to railway vehicles where no fixed connections are used between vehicle and infrastructure.

2 Normative references

The following documents, in whole or in part, are normatively referenced in this document and are indispensable for its application. For dated references, only the edition cited applies. For undated references, the latest edition of the referenced document (including any amendments) applies.

EN 1717, *Protection against pollution of potable water in water installations and general requirements of devices to prevent pollution by backflow*

EN 12663-1, *Railway applications - Structural requirements of railway vehicle bodies - Part 1: Locomotives and passenger rolling stock (and alternative method for freight wagons)*

EN 15877-2:2013, *Railway applications - Markings of railway vehicles - Part 2: External markings on coaches, motive power units, locomotives and on track machines*

EN 16362:2013, *Railway applications - Ground based services - Water restocking equipment*

EN 45545-2, *Railway applications - Fire protection on railway vehicles - Part 2: Requirements for fire behaviour of materials and components*

3 Terms and definitions

For the purposes of this document, the following terms and definitions apply.

3.1

railway infrastructure

all installations required for the running of railway vehicles including operating and support facilities

EXAMPLE Tracks, crossings, catenaries, signals, maintenance depots.

3.2

grey water

waste water from hand wash and galley sinks, usually contaminated with soap, germicides, residues of food, drink and dish water

3.3

servicing point

location where maintenance, refuelling and cleaning is carried out

3.4

controlled emission toilet

toilet system where the toilet waste is retained on the vehicle and emptied at prescribed locations, including on board waste treatment systems which are permitted to discharge some wastes at various locations

4 General

4.1 Description of vacuum

Vacuum can be expressed in different manners. Absolute vacuum is 0 bar and atmospheric pressure is nominally 1 bar (although this varies). When a vacuum pump evacuates 0,2 bar from a tank the remaining pressure within the tank is 0,8 bar (if the atmospheric pressure is 1 bar), but this can be expressed in a variety of ways. Therefore to avoid doubt, because the atmospheric pressure varies, throughout this standard vacuum is expressed as a negative number of bars below atmosphere (i.e. in the above example this is expressed within this standard as -0,2 bar).

Positive pressure is expressed as bars above atmosphere, i.e. in this standard an absolute pressure of 3 bar is shown as +2 bar.

4.2 Description of controlled emission toilet systems

There are five generic types of controlled emission toilets fitted to railway vehicles considered in this standard, shown diagrammatically in Annex A.

5 Requirements

5.1 General requirements

Each vehicle and servicing point shall be clearly marked with the type of system that is fitted, or intended to be used for. Adjacent to the connection on the vehicle and infrastructure the background, or if there is no background, an area beside the connection with a minimum dimension 60 mm x 60 mm, shall be coloured as shown in Table 1 and marked with the wording shown in Table 1 in the native language of the servicing point or the home depot of the vehicle and also at least in English. The labels shall be in a contrasting colour to the background colour.

Table 1 — Identification of toilet system

Type of system	Background colour The size of background colour shall be at least 60 mm x 60 mm:	Wording of label beside 3" connection	Wording of label beside 1" connection	Wording of label beside high pressure water connection
Compact system	Green	Toilet discharge	Flushing pipe	Not applicable
On line vacuum	Green	Toilet discharge	Flushing pipe	Not applicable
Permanent vacuum	Red	Toilet discharge, ensure ventilation is open	Flushing pipe	Not applicable
Chemical	Blue	Chemical toilet discharge	Flushing and chemical addition	Not applicable
On board waste treatment (e.g. bioreactor)	Yellow	On board waste treatment toilet discharge and cleaning	On board waste treatment water inlet and suction	On board waste treatment high pressure water
Catering area sink waste retention	Grey	Catering area sink waste	Not applicable	Not applicable

SS-EN 16922:2017+A1:2019 (E)

The position on a vehicle of the background colour and labels described in Table 1 is shown diagrammatically in Figure 1.

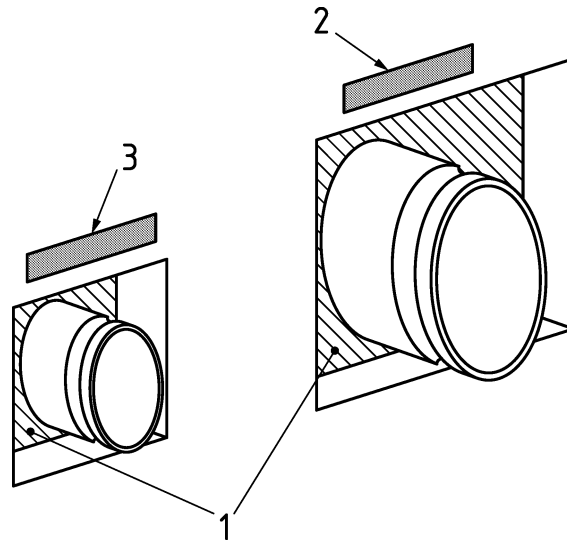

Key

- 1 background colour of type of system (as shown in Table 1)
- 2 label beside 3" connection
- 3 label beside 1" connection

Figure 1 — Identification of connections on vehicle

On the label shown in Figure 1, key 2, the volume of the retention tank in litres shall be indicated.

5.2 Vehicle requirements

5.2.1 Connections

Except for vehicles fitted with on board waste treatment system each vehicle with toilet waste or catering area sink waste retention tank shall be fitted with a connection as shown in Figure 2 on each side of vehicle. Vehicles fitted with on board waste treatment system are permitted to have the 3" connection on one side, but it is preferable to have on both sides.

For toilet waste retention tanks each such vehicle, excluding locomotives, shall also be fitted with a flushing connection as shown in Figure 3. On vehicles fitted with a chemical toilet system (Annex A, Figure A.4) the flushing connection shall be fitted on each side of the vehicle, for all other toilet systems the flushing connection shall be as a minimum of one side of the vehicle.

As design guidance it is preferable to have the flushing connection on both sides. It is also preferable to fit flushing connections for catering area sink waste tanks. Provision of the flushing connection reduces maintenance costs and increases efficiency of cleaning operations of the tank.

Dimensions in millimetres

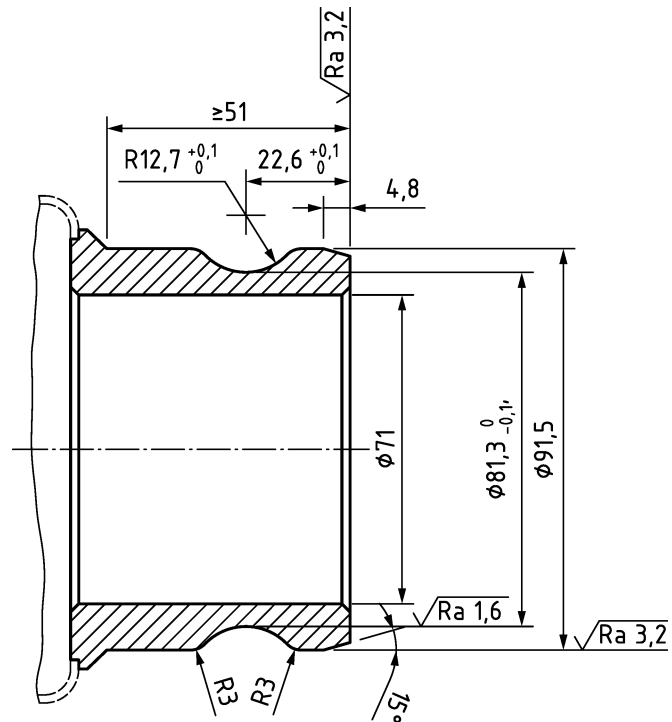

NOTE 1 General tolerances $\pm 0,1$.

NOTE 2 Material: stainless steel.

Figure 2 — 3" connection (inner part)

Dimensions in millimetres

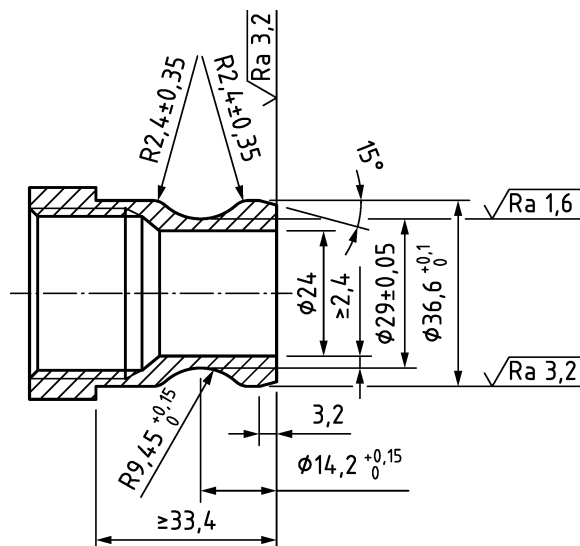

NOTE 1 General tolerances $\pm 0,1$.

NOTE 2 Material: stainless steel.

Figure 3 — 1" connection (inner part)