

SVENSK STANDARD

SS-ISO 10816-3:2009

Fastställt/Approved: 2009-02-09

Publicerad/Published: 2009-03-10

Utgåva/Edition: 2

Språk/Language: engelska/English

ICS: 17.160; 21.020; 27.040

**Vibration och stöt – Mätning och bedömning av maskin-
vibrationer på icke-roterande delar –
Del 3: Industriella maskiner med nominell effekt > 15 kW och
med nominellt varvtal mellan 120 r/min och 15000 r/min, mätt
på installerad maskin (ISO 10816-3:2009, IDT)**

**Mechanical vibration – Evaluation of machine vibration by
measurements on non-rotating parts –
Part 3: Industrial machines with nominal power above
15 kW and nominal speeds between 120 r/min
and 15 000 r/min when measured in situ
(ISO 10816-3:2009, IDT)**



SWEDISH
STANDARDS
INSTITUTE

Hitta rätt produkt och ett leveranssätt som passar dig

Standarder

Genom att följa gällande standard både effektiviserar och säkrar du ditt arbete. Många standarder ingår dessutom ofta i paket.

Tjänster

Abonnemang är tjänsten där vi uppdaterar dig med aktuella standarder när förändringar sker på dem du valt att abonnera på.

På så sätt är du säker på att du alltid arbetar efter rätt utgåva.

e-nav är vår online-tjänst som ger dig och dina kollegor tillgång till standarder ni valt att abonnera på dygnet runt. Med e-nav kan samma standard användas av flera personer samtidigt.

Leveranssätt

Du väljer hur du vill ha dina standarder levererade. Vi kan erbjuda dig dem på papper och som pdf.

Andra produkter

Vi har böcker som underlättar arbetet att följa en standard. Med våra böcker får du ökad förståelse för hur standarder ska följas och vilka fördelar den ger dig i ditt arbete. Vi tar fram många egna publikationer och fungerar även som återförsäljare. Det gör att du hos oss kan hitta över 500 unika titlar. Vi har även tekniska rapporter, specifikationer och "workshop agreement".

Matriser är en översikt på standarder och handböcker som bör läsas tillsammans. De finns på sis.se och ger dig en bra bild över hur olika produkter hör ihop.

Standardiseringsprojekt

Du kan påverka innehållet i framtida standarder genom att delta i någon av SIS ca 400 Tekniska Kommittéer.

Find the right product and the type of delivery that suits you

Standards

By complying with current standards, you can make your work more efficient and ensure reliability. Also, several of the standards are often supplied in packages.

Services

Subscription is the service that keeps you up to date with current standards when changes occur in the ones you have chosen to subscribe to. This ensures that you are always working with the right edition.

e-nav is our online service that gives you and your colleagues access to the standards you subscribe to 24 hours a day. With e-nav, the same standards can be used by several people at once.

Type of delivery

You choose how you want your standards delivered. We can supply them both on paper and as PDF files.

Other products

We have books that facilitate standards compliance. They make it easier to understand how compliance works and how this benefits you in your operation. We produce many publications of our own, and also act as retailers. This means that we have more than 500 unique titles for you to choose from. We also have technical reports, specifications and workshop agreements.

Matrices, listed at sis.se, provide an overview of which publications belong together.

Standardisation project

You can influence the content of future standards by taking part in one or other of SIS's 400 or so Technical Committees.

Den internationella standarden ISO 10816-3:2009 gäller som svensk standard. Detta dokument innehåller den officiella engelska versionen av ISO 10816-3:2009.

Denna standard ersätter SS-ISO 10816-3, utgåva 1.

The International Standard ISO 10816-3:2009 has the status of a Swedish Standard. This document contains the official English version of ISO 10816-3:2009.

This standard supersedes the Swedish Standard SS-ISO 10816-3, edition 1.

© Copyright/Upphovsrätten till denna produkt tillhör SIS, Swedish Standards Institute, Stockholm, Sverige. Användningen av denna produkt regleras av slutanvändarlicensen som återfinns i denna produkt, se standardens sista sidor.

© Copyright SIS, Swedish Standards Institute, Stockholm, Sweden. All rights reserved. The use of this product is governed by the end-user licence for this product. You will find the licence in the end of this document.

Upplysningar om sakinnehållet i standarden lämnas av SIS, Swedish Standards Institute, telefon 08-555 520 00. Standarder kan beställas hos SIS Förlag AB som även lämnar allmänna upplysningar om svensk och utländsk standard.

Information about the content of the standard is available from the Swedish Standards Institute (SIS), tel +46 8 555 520 00. Standards may be ordered from SIS Förlag AB, who can also provide general information about Swedish and foreign standards.

SIS Förlag AB, SE 118 80 Stockholm, Sweden. Tel: +46 8 555 523 10. Fax: +46 8 555 523 11.
E-mail: sis.sales@sis.se Internet: www.sis.se

Contents	Page
Foreword	iv
Introduction	v
1 Scope	1
2 Normative references	2
3 Measurement procedures and operational conditions	2
4 Machine classification	5
5 Evaluation	6
Annex A (normative) Evaluation zone boundaries	10
Bibliography	12

Foreword

ISO (the International Organization for Standardization) is a worldwide federation of national standards bodies (ISO member bodies). The work of preparing International Standards is normally carried out through ISO technical committees. Each member body interested in a subject for which a technical committee has been established has the right to be represented on that committee. International organizations, governmental and non-governmental, in liaison with ISO, also take part in the work. ISO collaborates closely with the International Electrotechnical Commission (IEC) on all matters of electrotechnical standardization.

International Standards are drafted in accordance with the rules given in the ISO/IEC Directives, Part 2.

The main task of technical committees is to prepare International Standards. Draft International Standards adopted by the technical committees are circulated to the member bodies for voting. Publication as an International Standard requires approval by at least 75 % of the member bodies casting a vote.

Attention is drawn to the possibility that some of the elements of this document may be the subject of patent rights. ISO shall not be held responsible for identifying any or all such patent rights.

ISO 10816-3 was prepared by Technical Committee ISO/TC 108, *Mechanical vibration, shock and condition monitoring*, Subcommittee SC 2, *Measurement and evaluation of mechanical vibration and shock as applied to machines, vehicles and structures*.

This second edition cancels and replaces the first edition (ISO 10816-3:1998). The main change is the deletion of pumps from the scope, which now are dealt with in ISO 10816-7.

ISO 10816 consists of the following parts, under the general title *Mechanical vibration — Evaluation of machine vibration by measurements on non-rotating parts*:

- *Part 1: General guidelines*
- *Part 2: Land-based steam turbines and generators in excess of 50 MW with normal operating speeds of 1 500 r/min, 1 800 r/min, 3 000 r/min and 3 600 r/min*
- *Part 3: Industrial machines with nominal power above 15 kW and nominal speeds between 120 r/min and 15 000 r/min when measured in situ*
- *Part 4: Gas turbine sets with fluid-film bearings*
- *Part 5: Machine sets in hydraulic power generating and pumping plants*
- *Part 6: Reciprocating machines with power ratings above 100 kW*
- *Part 7: Rotodynamic pumps for industrial applications, including measurements on rotating shafts*

Introduction

ISO 10816-1 is the basic document describing the general requirements for evaluating the vibration of various machine types when the vibration measurements are made on non-rotating parts. This part of ISO 10816 provides specific guidance for assessing the severity of vibration measured on bearings, bearing pedestals, or housings of industrial machines when measurements are made *in situ*.

Two criteria are provided for assessing the machine vibration. One criterion considers the magnitude of the observed vibration; the second considers the changes in the magnitude. It must be recognized, however, that these criteria do not form the only basis for judging the severity of vibration. For some machine types, it is also common to judge the vibration based on measurements taken on the rotating shafts. Shaft vibration measurement requirements and criteria are addressed in separate documents, namely ISO 7919-1^[1] and ISO 7919-3^[2].

Mechanical vibration — Evaluation of machine vibration by measurements on non-rotating parts —

Part 3:

Industrial machines with nominal power above 15 kW and nominal speeds between 120 r/min and 15 000 r/min when measured *in situ*

1 Scope

This part of ISO 10816 gives criteria for assessing vibration levels when measurements are made *in situ*. The criteria specified apply to machine sets having a power above 15 kW and operating speeds between 120 r/min and 15 000 r/min.

The machine sets covered by this part of ISO 10816 include:

- steam turbines with power up to 50 MW;
- steam turbine sets with power greater than 50 MW and speeds below 1 500 r/min or above 3 600 r/min (not included in ISO 10816-2);
- rotary compressors;
- industrial gas turbines with power up to 3 MW;
- generators;
- electrical motors of any type;
- blowers or fans.

NOTE However, the vibration criteria presented in this part of ISO 10816 are generally only applicable to fans with power ratings greater than 300 kW or fans which are not flexibly supported. As and when circumstances permit, recommendations for other types of fans, including those with lightweight sheet metal construction, will be prepared. Until such time, classifications can be agreed between the manufacturer and the customer, using results of previous operational experience, see also ISO 14694^[4].

The following are excluded from this part of ISO 10816:

- land-based steam turbine generator sets with power greater than 50 MW and speeds of 1 500 r/min, 1 800 r/min, 3 000 r/min or 3 600 r/min (see ISO 10816-2);
- gas turbine sets with power greater than 3 MW (see ISO 10816-4);
- machine sets in hydraulic power generating and pumping plants (see ISO 10816-5);
- machines coupled to reciprocating machines (see ISO 10816-6);

SS-ISO 10816-3:2009 (E)

- rotodynamic pumps including integrated electric motors, i.e. where the impeller is mounted directly on the motor shaft or is rigidly attached to it (see ISO 10816-7);
- rotary positive displacement compressors (e. g. screw compressors);
- reciprocating compressors;
- reciprocating pumps;
- submerged motor-pumps;
- wind turbines.

The criteria of this part of ISO 10816 apply to *in situ* broad-band vibration measurements taken on the bearings, bearing pedestals, or housing of machines under steady-state operating conditions within the nominal operating speed range. They relate to both acceptance testing and operational monitoring. The evaluation criteria of this part of ISO 10816 are designed to apply to both continuous and non-continuous monitoring situations.

This part of ISO 10816 encompasses machines which may have gears or rolling element bearings, but does not address the diagnostic evaluation of the condition of those gears or bearings.

The criteria are applicable only for the vibration produced by the machine set itself and not for vibration which is transmitted to the machine set from external sources.

2 Normative references

The following referenced documents are indispensable for the application of this document. For dated references, only the edition cited applies. For undated references, the latest edition of the referenced document (including any amendments) applies.

ISO 496, *Driving and driven machines — Shaft heights*

ISO 2954, *Mechanical vibration of rotating and reciprocating machinery — Requirements for instruments for measuring vibration severity*

ISO 10816-1, *Mechanical vibration — Evaluation of machine vibration by measurements on non-rotating parts — Part 1: General guidelines*

3 Measurement procedures and operational conditions

3.1 General

The general measurement procedures are in accordance with ISO 10816-1, subject to the recommendations specified below.

3.2 Measurement equipment

The measurement equipment shall be capable of measuring broad-band root-mean-square (r.m.s.) vibration with flat response over a frequency range of at least 10 Hz to 1 000 Hz in accordance with the requirements of ISO 2954. Depending on the vibration criteria, this may require measurements of displacement or velocity or combinations of these (see ISO 10816-1). However, for machines with speeds approaching or below 600 r/min, the lower limit of the flat response frequency range shall not be greater than 2 Hz.

NOTE If the measurement equipment is also to be used for diagnostic purposes, an upper frequency limit higher than 1 000 Hz may be necessary.

Care should be taken to ensure that the measuring system is not influenced by environmental factors such as:

- temperature variations;
- magnetic fields;
- sound fields;
- power source variations;
- transducer cable length;
- transducer orientation.

Particular attention should be given to ensure that the vibration transducers are correctly mounted and that such mountings do not degrade the accuracy of the measurements.

3.3 Measurement locations

Measurements will usually be taken on exposed parts of the machine that are normally accessible. Care shall be taken to ensure that measurements reasonably represent the vibration of the bearing housing and do not include any local resonances or amplification. The locations and directions of vibration measurements shall be such that they provide adequate sensitivity to the machine dynamic forces. Typically, this will require two orthogonal radial measurement locations on each bearing cap or pedestal, as shown in Figure 1 (for horizontally mounted machines) and Figure 2 (for vertically mounted machines).

NOTE Figure 2, which is taken from IEC 60034-14:2003^[5], shows a motor mounted vertically on a solid steel plate or flange (e.g. of a driven machine) with a bore hole in the centre of the shaft extension. The main purpose of this figure is to identify the measuring points for a vertical machine.

The transducers may be placed at any angular position on the bearing housings or pedestals. Vertical and horizontal directions are usually preferred for horizontally mounted machines. For vertical or inclined machines, the location that gives the maximum vibration reading, usually in the direction of the elastic axis, shall be one of those used. In some cases it may be recommended to measure also in the axial direction (see 5.2.4). The specific locations and directions shall be recorded with the measurement.

A single transducer may be used on a bearing cap or pedestal in place of the more typical pair of orthogonal transducers if it is known to provide adequate information on the magnitude of the machine vibration. However, caution should be observed when evaluating vibration from a single transducer at a measurement plane since it may not be oriented to provide a reasonable approximation to the maximum value at that plane.

3.4 Continuous and non-continuous monitoring

It is common practice on large or critical machinery to have installed instrumentation for continuous on-line monitoring of vibration values at key measurement points. For many machines, mainly those of small size or power, continuous monitoring of the vibration parameters is not necessarily carried out. Changes in unbalance, bearing performance, alignment, etc. can be detected with sufficient reliability from periodic measurements with permanently installed or hand-held instruments. The use of computers for trend analysis and warning against malfunctions is also becoming more common.

3.5 Operational conditions

Measurements shall be carried out when the rotor and the main bearings have reached their normal steady-state operating temperatures and with the machine running under specified conditions, for example at rated speed, voltage, flow, pressure and load.

On machines with varying speeds or loads, measurements shall be made at all conditions at which the machine would be expected to operate for prolonged periods. The maximum measured value under these conditions shall be considered representative of vibration severity.

SS-ISO 10816-3:2009 (E)

If the measured vibration is greater than the acceptance criteria allowed and excessive background vibration is suspected, measurements should be made with the machine shut down to determine the degree of external influence. If the vibration with the machine stationary exceeds 25 % of the value measured when the machine is running, corrective action may be necessary to reduce the effect of background vibration.

NOTE In some cases the effect of background vibration may be nullified by spectrum analysis or by eliminating the offending external source.

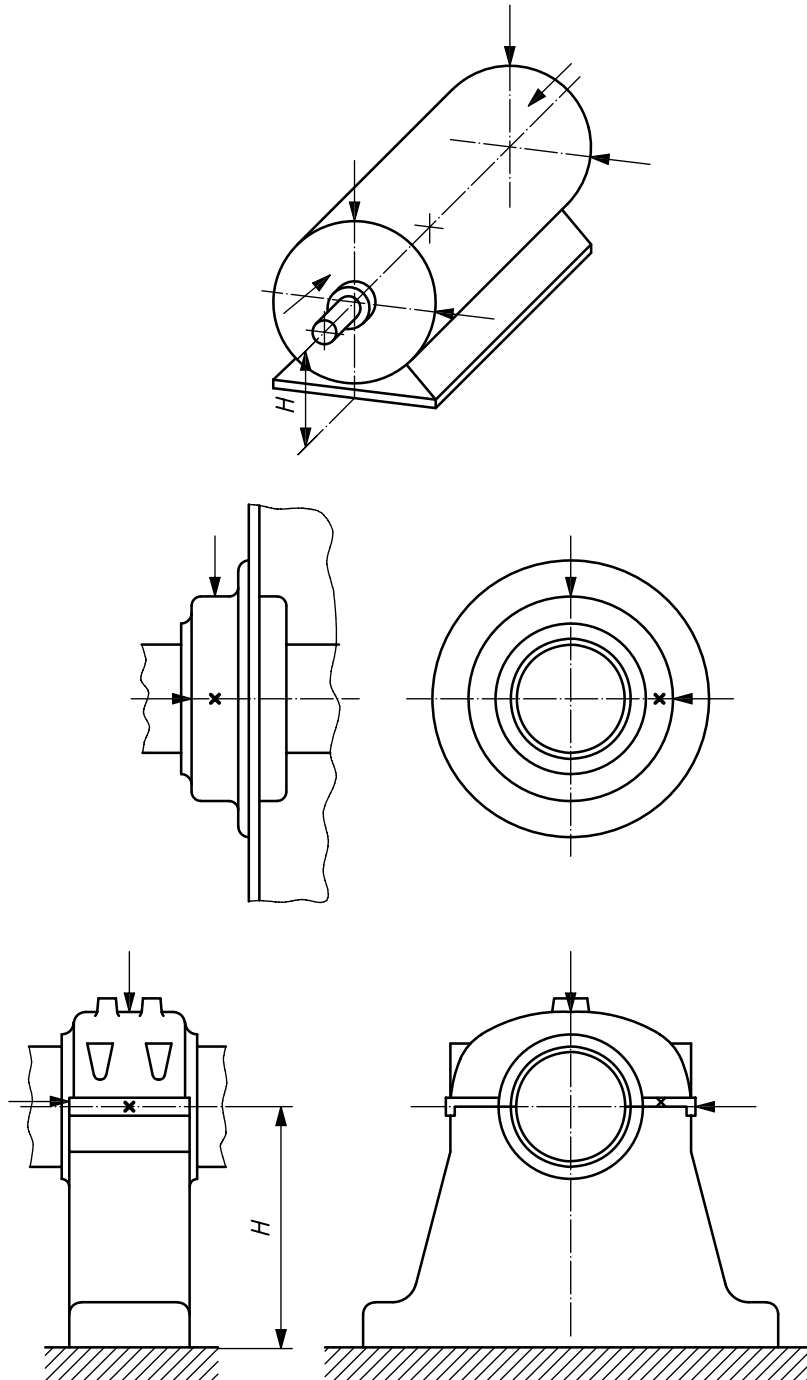

NOTE Measurements to be made at the bearing housing or, if not accessible, then at positions as close as possible to the bearing housings which provide adequate sensitivity to the machine dynamic forces.

Figure 1 — Measuring points for a horizontally mounted machine

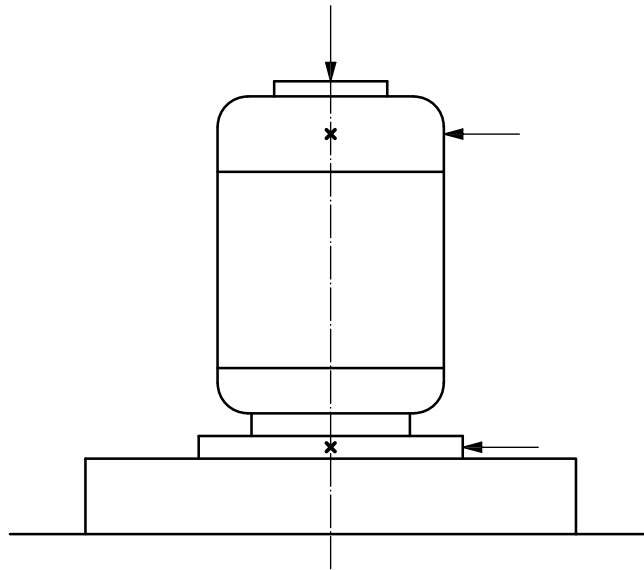

NOTE Measurements to be made at the bearing housing or, if not accessible, then at positions as close as possible to the bearing housings which provide adequate sensitivity to the machine dynamic forces.

Figure 2 — Measuring points for a vertically mounted machine

4 Machine classification

4.1 General

In this part of ISO 10816, the vibration severity is classified according to the following parameters:

- machine type;
- rated power or shaft height;
- support system flexibility.

4.2 Classification according to machine type, rated power or shaft height

Significant differences in design, type or bearings and support structures require a separation into two different machine groups (the shaft height, H , is in accordance with ISO 496). Machines of these two groups may have horizontal, vertical or inclined shafts and can be mounted on rigid or flexible supports.

Group 1: Large machines with rated power above 300 kW; electrical machines with shaft height $H \geq 315$ mm.

These machines normally have sleeve bearings. The range of operating or nominal speeds is relatively broad and ranges from 120 r/min to 15 000 r/min.

Group 2: Medium-sized machines with a rated power above 15 kW up to and including 300 kW; electrical machines with shaft height $160 \text{ mm} \leq H < 315$ mm.

These machines normally have rolling element bearings and operating speeds above 600 r/min.

NOTE 1 The shaft height, H , of a machine is defined in accordance with ISO 496 as the distance, measured on the machine ready for delivery, between the centreline of the shaft and the base plane of the machine itself (see Figure 1).

NOTE 2 The shaft height of a machine without feet, or a machine with raised feet, or any vertical machine, is to be taken as the shaft height of a machine in the same basic frame, but of the horizontal shaft foot-mounting type. When the frame is unknown, half of the machine diameter should be used.