



SWEDISH
STANDARDS
INSTITUTE

**SVENSK STANDARD
SS-EN 284:2006**

Fastställd 2006-10-30

Utgåva 2

**Växelflak – Ej staplingsbara, klass C – Mått och
allmänna krav**

**Swap bodies – Non-stackable swap bodies of
class C – Dimensions and general requirements**

ICS 55.180.10

Språk: engelska

Publicerad: december 2006

Europastandarden EN 284:2006 gäller som svensk standard. Detta dokument innehåller den officiella engelska versionen av EN 284:2006.

Denna standard ersätter SS-EN 284, utgåva 1.

The European Standard EN 284:2006 has the status of a Swedish Standard. This document contains the official English version of EN 284:2006.

This standard supersedes SS-EN 284, edition 1.

Upplysningar om **sakinnehållet** i standarden lämnas av SIS, Swedish Standards Institute, telefon 08 - 555 520 00.

Standarder kan beställas hos SIS Förlag AB som även lämnar **allmänna upplysningar** om svensk och utländsk standard.

Postadress: SIS Förlag AB, 118 80 STOCKHOLM
Telefon: 08 - 555 523 10. *Telefax:* 08 - 555 523 11
E-post: sis.sales@sis.se. *Internet:* www.sis.se

EUROPEAN STANDARD

EN 284

NORME EUROPÉENNE

EUROPÄISCHE NORM

October 2006

ICS 55.180.10

Supersedes EN 284:1992

English Version

Swap bodies - Non-stackable swap bodies of class C - Dimensions and general requirements

Caisses mobiles - Caisses mobiles non-gerbables de
classe C - Dimensions et spécifications générales

Wechselbehälter - Nicht stapelbare Wechselbehälter der
Klasse C - Maße und allgemeine Anforderungen

This European Standard was approved by CEN on 11 September 2006.

CEN members are bound to comply with the CEN/CENELEC Internal Regulations which stipulate the conditions for giving this European Standard the status of a national standard without any alteration. Up-to-date lists and bibliographical references concerning such national standards may be obtained on application to the Central Secretariat or to any CEN member.

This European Standard exists in three official versions (English, French, German). A version in any other language made by translation under the responsibility of a CEN member into its own language and notified to the Central Secretariat has the same status as the official versions.

CEN members are the national standards bodies of Austria, Belgium, Cyprus, Czech Republic, Denmark, Estonia, Finland, France, Germany, Greece, Hungary, Iceland, Ireland, Italy, Latvia, Lithuania, Luxembourg, Malta, Netherlands, Norway, Poland, Portugal, Romania, Slovakia, Slovenia, Spain, Sweden, Switzerland and United Kingdom.



EUROPEAN COMMITTEE FOR STANDARDIZATION
COMITÉ EUROPÉEN DE NORMALISATION
EUROPÄISCHES KOMITEE FÜR NORMUNG

Management Centre: rue de Stassart, 36 B-1050 Brussels

EN 284:2006 (E)

Contents		Page
Foreword.....		3
Introduction		4
1	Scope	5
2	Normative references	5
3	Dimensions and ratings	5
4	Strength requirements	6
5	Design requirements	7
6	Optional features	14
7	Marking	15
Annex A (normative) Bottom fittings		16
Annex B (normative) Supporting legs with safety device		17
Bibliography		22

Foreword

This document (EN 284:2006) has been prepared by Technical Committee CEN/TC 119 "Swap bodies for combined transport", the secretariat of which is held by DIN.

This European Standard shall be given the status of a national standard, either by publication of an identical text or by endorsement, at the latest by April 2007, and conflicting national standards shall be withdrawn at the latest by April 2007.

This document supersedes EN 284:1992.

Attention is drawn to the possibility that some of the elements of this document may be the subject of patent rights. CEN [and/or CENELEC] shall not be held responsible for identifying any or all such patent rights.

According to the CEN/CENELEC Internal Regulations, the national standards organizations of the following countries are bound to implement this European Standard: Austria, Belgium, Cyprus, Czech Republic, Denmark, Estonia, Finland, France, Germany, Greece, Hungary, Iceland, Ireland, Italy, Latvia, Lithuania, Luxembourg, Malta, Netherlands, Norway, Poland, Portugal, Romania, Slovakia, Slovenia, Spain, Sweden, Switzerland and the United Kingdom.

EN 284:2006 (E)

Introduction

Non stackable swap bodies of class C are intended for use in the international exchange of goods and for their transportation by road and rail, including interchange between these modes of transport, but not intended for the carriage by container ships. They are equipped with bottom corner fittings positioned in accordance with ISO 668.

1 Scope

This European Standard specifies basic requirements for non-stackable swap bodies of class C, having a gross mass of not more than 16 t.

NOTE 1 "Swap bodies of class C" means that they are equipped with bottom fittings positioned according to the specification for 1 C (20') ISO containers (see ISO 668).

NOTE 2 Stackable swap bodies class C are specified in CEN/TS 13853.

2 Normative references

The following referenced documents are indispensable for the application of this document. For dated references, only the edition cited applies. For undated references, the latest edition of the referenced document (including any amendments) applies.

EN 283:1991, *Swap bodies — Testing*

EN 12640, *Securing of cargo on road vehicles — Lashing points on commercial vehicles for goods transportation — Minimum requirements and testing*

EN 12641-1, *Swap bodies and commercial vehicles — Tarpaulins — Part 1: Minimum requirements*

EN 12641-2, *Swap bodies and commercial vehicles — Tarpaulins — Part 2: Minimum requirements for curtainsiders*

EN 12642, *Securing of cargo on road vehicles — Body structure of commercial vehicles — Minimum requirements*

EN 13044, *Swap bodies — Coding, identification and marking*

ISO 1161, *Series 1 freight containers — Corner fittings — Specification*

UIC¹⁾ 596-6; *Conveyance of road vehicles on wagons — Technical organisation — Conditions for coding combined-transport load units and combined-transport lines*

3 Dimensions and ratings

The external dimensions, tolerances and rating (*R*) of the swap bodies covered by this European Standard are specified in Figure 1 and Table 1. No part of the swap body shall project beyond the boundaries defined by the external dimensions.

1) Union Internationale des Chemins de Fer, 16, rue Jean Rey, F-75015 Paris (<http://www.uic.asso.fr/>).

EN 284:2006 (E)

Dimensions in millimetres

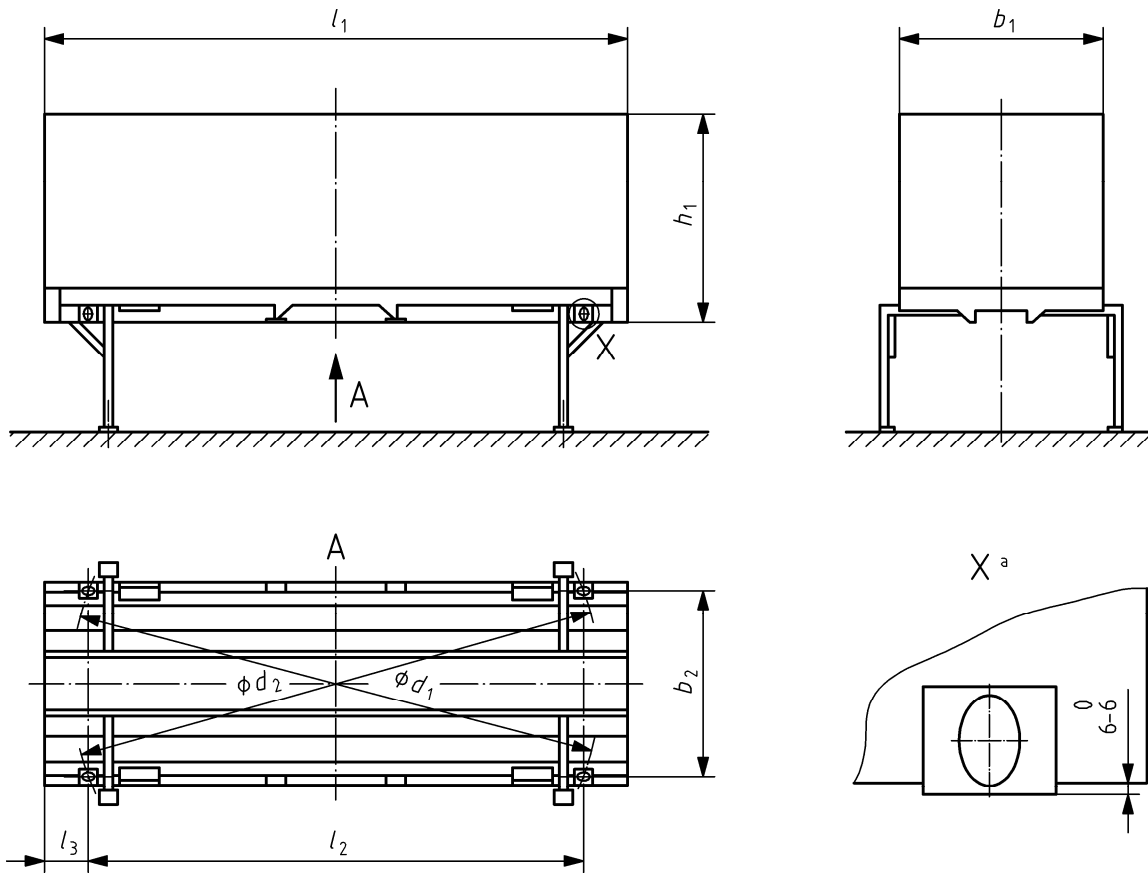

Key

a detail, showing the position of the lower corner castings

Figure 1 — Basic dimensions

Table 1 — Dimensions and rating

Swap body designation	Dimensions in millimetres							
	l_1	l_2	l_3	h_1^a (nominal)	b_1^b	b_2	$d_1 - d_2$ or $d_2 - d_1$	R
C 745	7450_{-20}^0	5853 ± 3	$798,5_{-3}^0$	2 750	2550_{-10}^0	2259 ± 3	13 max.	16 t max.
C 782^c	7820_{-20}^0		$983,5_{-3}^0$					

^a The International Union of Railways code for line categories UIC 596-6 shall be taken into consideration to assure transportation without hindrance on the main railways lines of continental Europe.

^b A maximum width of 2 600 mm is permitted for certain thermal bodies according to EC Directive No. 96/53/EC.

^c According to present road vehicle legislation in certain countries, the transport of two swap bodies of this size on a road train is only feasible when used together with a short coupling.

4 Strength requirements

The strength requirements for non-stackable swap bodies are given in EN 283.

5 Design requirements

5.1 Bottom fittings

5.1.1 Swap bodies shall be equipped with four bottom fittings positioned in accordance with Figure 1 and Table 1.

5.1.2 The apertures and basic dimensions of the bottom fittings shall comply with Annex A.

5.2 Grappler arm lifting areas

5.2.1 Swap bodies shall be equipped with four grappler arm lifting areas located as shown in Figure 2. Requirements for the location and dimensions of these areas are given in Figures 3 and 4.

5.2.2 The total length of each grappler arm lifting area shall be in compliance with one of the following conditions:

- a) 850 mm as measured from the axis of the adjacent bottom fittings – additional end stop in swap body longitudinal direction are not required;
- b) 500 mm if fitted with additional end stop in swap body longitudinal direction on either side of that area.

5.2.3 The safety lip, which forms an integral part of the grappler arm lifting area, must have a minimum length of 500 mm, whichever of the two solutions above applied; i.e. if the total length of the grappler arm lifting area is 850 mm, the safety lip may be removed as shown in Figures 3d), 3e) and 4a), 4b), 4c) and 4d).

5.2.4 For box type swap bodies only the provision of a wear-resistant plate is recommended to protect the side walls. Such a plate shall not protrude beyond the outer plane of the grappler arm position, an offset of ≤ 2 mm is possible. For all other types (i.e. tarpaulin and curtainsiders) it is recommended that the curtain shall be reinforced in the grappler arm contact area.

Dimensions in millimetres

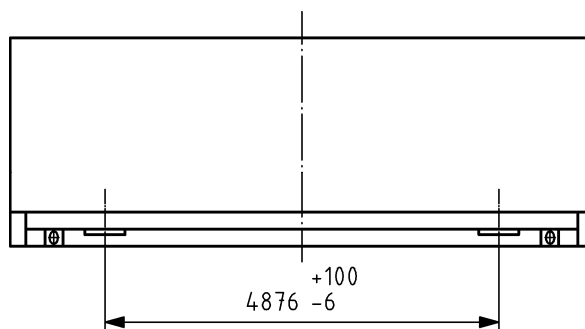

Figure 2 — Side view with grappler arm lifting areas

Dimensions in millimetres

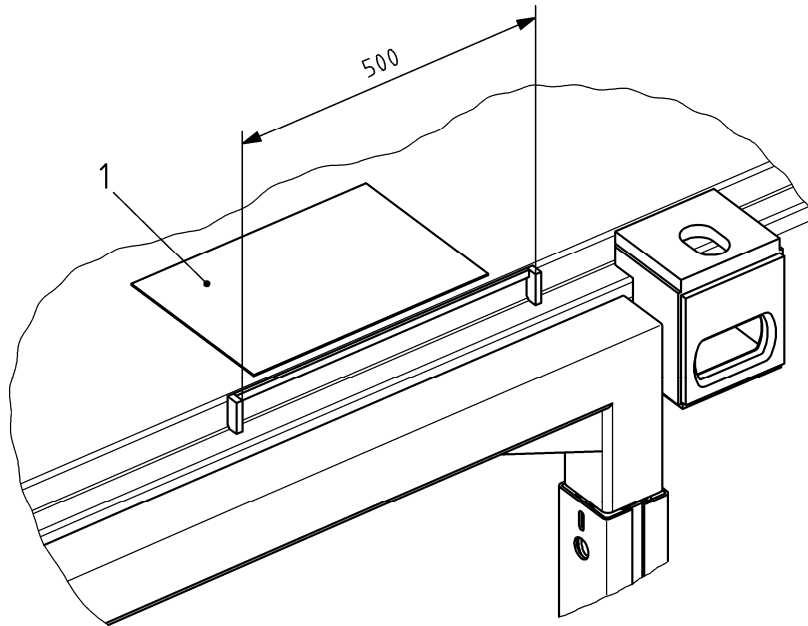

Figure 3a) — Grappler flange safety lip, end stops and wear-resistant plate – three dimensional view, seen from the bottom

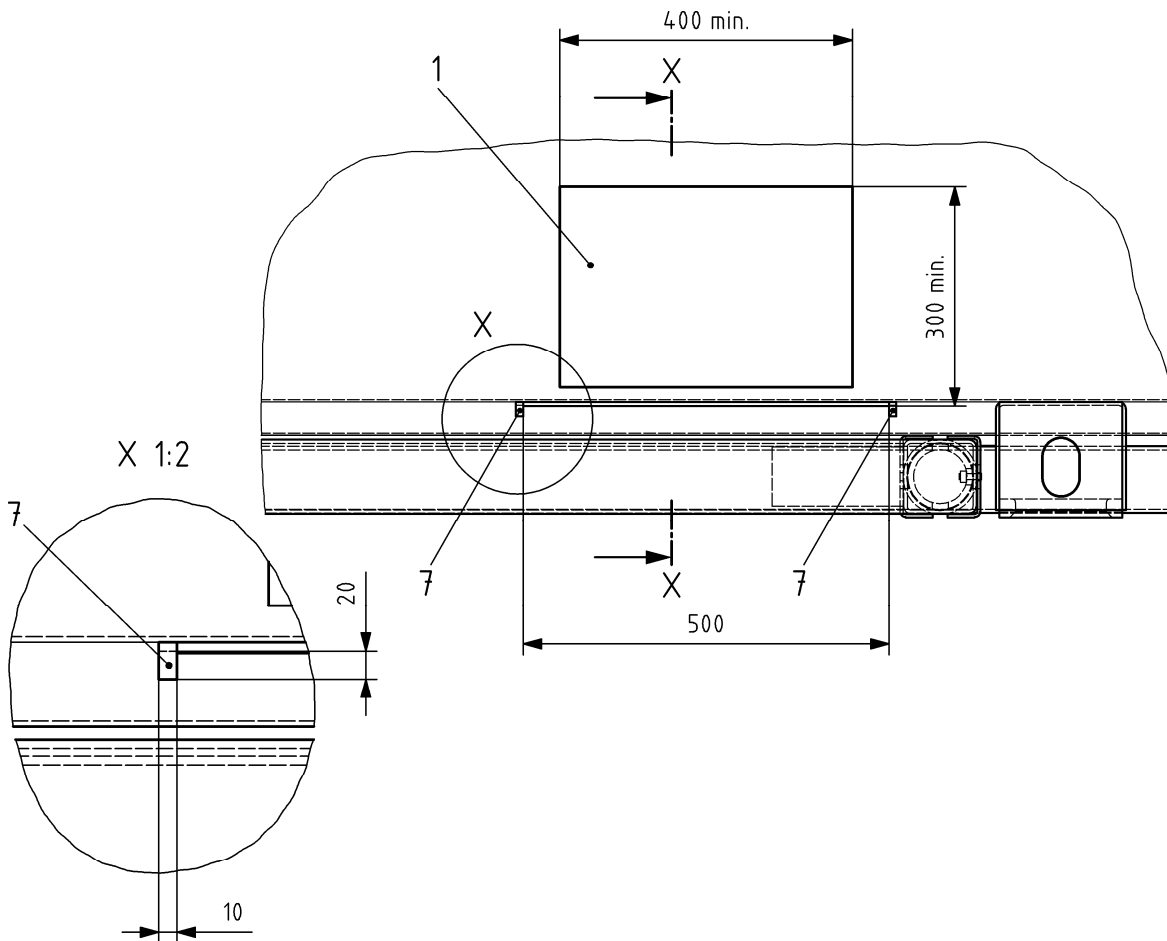

Figure 3b) — Grappler flange safety lip, end stops and wear-resistant plate – side view

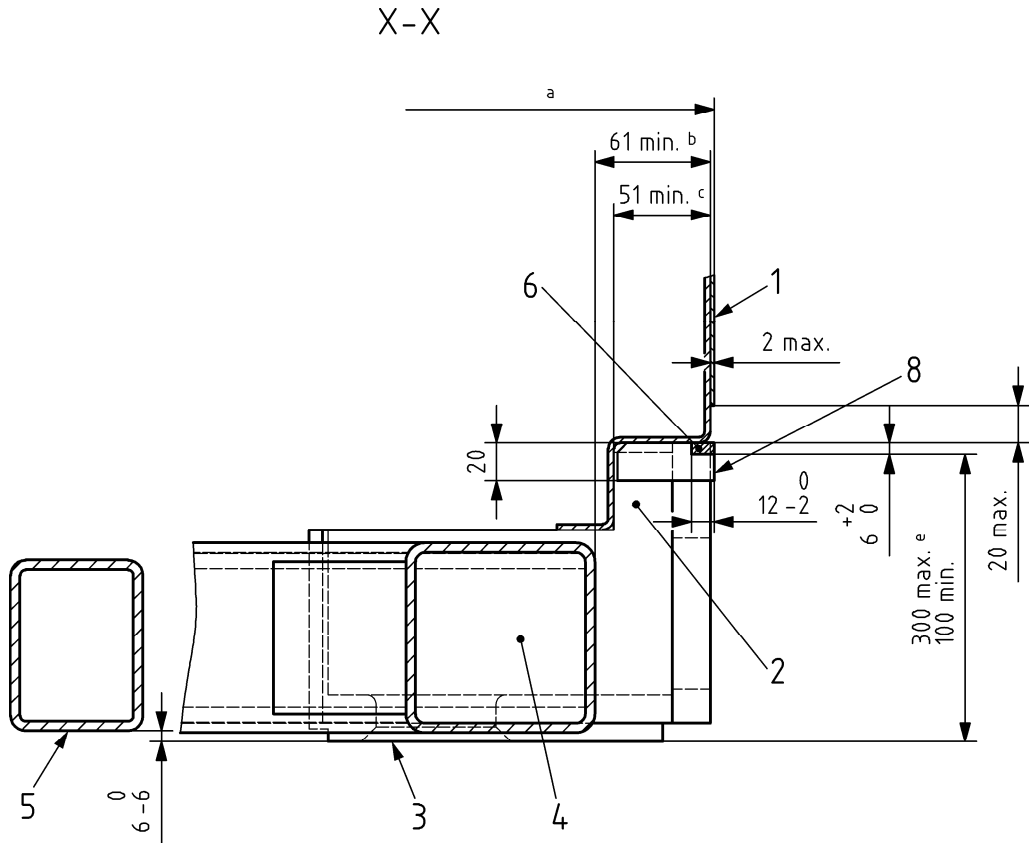

Figure 3c) — Grapppler flange safety lip, end stops and wear-resistant plate – Section X-X

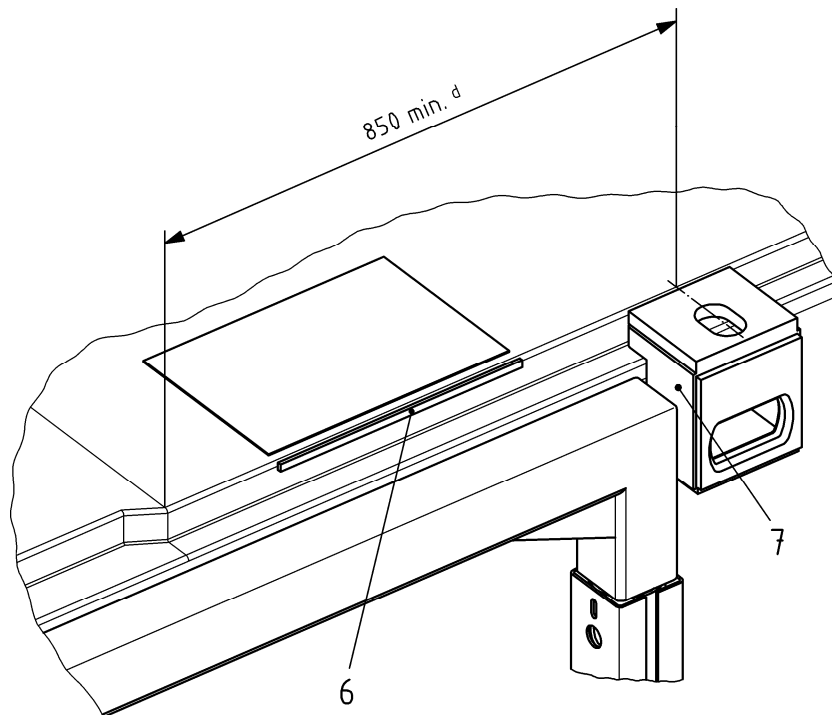

Figure 3d) — Grapppler flange safety lip with corner casting as end stop – three dimensional view, seen from the bottom