

**Vägfordon – Svänghjul för förbränningsmotorer –
Dimensioner för koppling (ISO 11055:1996, IDT)**

**Flywheels for reciprocating internal combustion
engines – Installation dimensions for clutches
(ISO 11055:1996, IDT)**

Uppllysningar om **sakinnehållet** i standarden lämnas av SIS, Swedish Standards Institute, telefon 08 - 555 520 00.

Standarder kan beställas hos SIS Förlag AB som även lämnar **allmänna uppllysningar** om svensk och utländsk standard.

Postadress: SIS Förlag AB, 118 80 STOCKHOLM

Telefon: 08 - 555 523 10. *Telefax:* 08 - 555 523 11

E-post: sis.sales@sis.se. *Internet:* www.sis.se

Den internationella standarden ISO 11055:1986 gäller som svensk standard. Detta dokument innehåller den officiella engelska versionen av ISO 11055:1986.

The International Standard ISO 11055:1986 has the status of a Swedish Standard. This document contains the official English version of ISO 11055:1986.

SS-ISO 11055:2005

Foreword

ISO (the International Organization for Standardization) is a worldwide federation of national standards bodies (ISO member bodies). The work of preparing International Standards is normally carried out through ISO technical committees. Each member body interested in a subject for which a technical committee has been established has the right to be represented on that committee. International organizations, governmental and non-governmental, in liaison with ISO, also take part in the work. ISO collaborates closely with the International Electrotechnical Commission (IEC) on all matters of electrotechnical standardization.

Draft International Standards adopted by the technical committees are circulated to the member bodies for voting. Publication as an International Standard requires approval by at least 75 % of the member bodies casting a vote.

International Standard ISO 11055 was prepared by Technical Committee ISO/TC 22, *Road vehicles*, Subcommittee SC 15, *Interchangeability of components of commercial vehicles and buses*.

Annex A of this International Standard is for information only.

© ISO 1996

All rights reserved. Unless otherwise specified, no part of this publication may be reproduced or utilized in any form or by any means, electronic or mechanical, including photocopying and microfilm, without permission in writing from the publisher.

International Organization for Standardization
Case Postale 56 • CH-1211 Genève 20 • Switzerland

Printed in Switzerland

Flywheels for reciprocating internal combustion engines — Installation dimensions for clutches

1 Scope

This International Standard specifies the nominal dimensions and tolerances which affect the interchangeability between flywheels and spring-loaded single- or two-plate clutches.

The flywheels are for use on reciprocating internal combustion engines in conjunction with flywheel housings and clutch housings which are dealt with in ISO 7648^[1] and ISO 7649^[2].

Dimensions and tolerances not specified are left to the discretion of the component manufacturer.

This International Standard applies to reciprocating internal combustion engines, with the exception of engines for aircraft and passenger cars; it may be used for other engine applications where no specific International Standard exists.

NOTE — It is recognized that the dimensions shown in this International Standard may not be suitable for some designs in use at present, but they should be used for all new designs as a means of achieving rationalization in the future.

2 Normative references

The following standards contain provisions which, through reference in this text, constitute provisions of this International Standard. At the time of publication, the editions indicated were valid. All standards are subject to revision, and parties to agreements based on this International Standard are encouraged to investigate the possibility of applying the most recent editions of the standards indicated below. Members of IEC and ISO maintain registers of currently valid International Standards.

ISO 286-2:1988, *ISO system of limits and fits — Part 2: Tables of standard tolerance grades and limit deviations for holes and shafts*.

ISO 1101:1983, *Technical drawings — Geometrical tolerancing — Tolerancing of form, orientation, location and run-out — Generalities, definitions, symbols, indications on drawings*.

3 Flywheel types and specifications

This International Standard defines two types of flywheel:

- flat type [see figure 1 a)];
- pot type [see figure 1 b)].

SS-ISO 11055:2005

Both types are specified for clutch centring either by spigot or dowels. Dowel holes are specified on the same pitch circle diameter as tapped holes.

For dimensions and tolerances in figure 1, see tables 1 and 2. For definitions and symbols for geometrical tolerances, see ISO 1101.

4 Tapped holes and dowels

Any variation in tapped hole or dowel pattern and/or size shall be subject to agreement between engine manufacturers and clutch suppliers, including the eventuality of stepped dowels being required.

Dimensions in millimetres

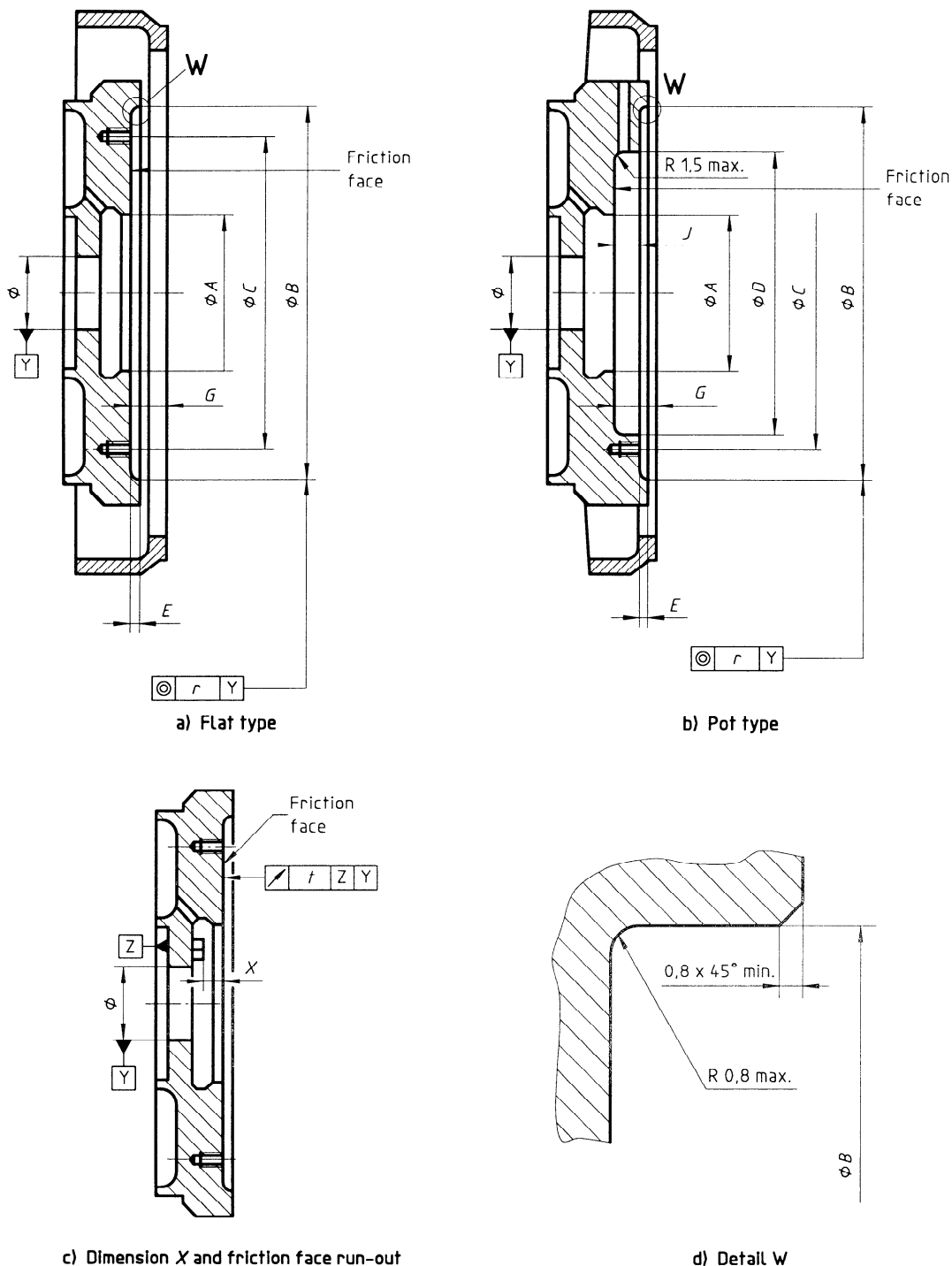

Figure 1 — Flywheels