



Handläggande organ	Fastställt	Utgåva	Sida
SVENSK MATERIAL- & MEKANSTANDARD, SMS	1999-12-03	1	1 (1+22)

© Copyright SIS. Reproduction in any form without permission is prohibited.

Non-destructive testing – Radioscopic testing – Part 1: Quantitative measurement of imaging properties

The European Standard EN 13068-1:1999 has the status of a Swedish Standard. This document contains the official English version of EN 13068-1:1999.

Swedish Standards corresponding to documents referred to in this Standard are listed in "Catalogue of Swedish Standards", issued by SIS. The Catalogue lists, with reference number and year of Swedish approval, International and European Standards approved as Swedish Standards as well as other Swedish Standards.

Oförstörande provning – Radioskopi – Del 1: Kvantitativ mätning av avbildningsenhetens egenskaper

Europastandarden EN 13068-1:1999 gäller som svensk standard. Detta dokument innehåller den officiella engelska versionen av EN 13068-1:1999.

Motsvarigheten och aktualiteten i svensk standard till de publikationer som omnämns i denna standard framgår av "Katalog över svensk standard", som ges ut av SIS. I katalogen redovisas internationella och europeiska standarder som fastställts som svenska standarder och övriga gällande svenska standarder.

ICS 19.100

Standarder kan beställas hos SIS Förlag AB som även lämnar allmänna upplysningar om svensk och utländsk standard. *Postadress:* SIS, Box 6455, 113 82 STOCKHOLM
Telefon: 08 - 610 30 00. *Telefax:* 08 - 30 77 57

Upplysningar om **sakinnehållet** i standarden lämnas av SMS.
Telefon: 08 - 459 56 00. *Telefax:* 08 - 667 85 42
E-post: info@sms-standard.se
Prisgrupp Q

Tryckt i februari 2000

EUROPEAN STANDARD
NORME EUROPÉENNE
EUROPÄISCHE NORM

EN 13068-1

December 1999

ICS 19.100

English version

Non-destructive testing - Radioscopic testing - Part 1: Quantitative measurement of imaging properties

Essais non destructifs - Contrôle par radioscopie - Partie 1:
Mesure quantitative des caractéristiques d'image

Zerstörungsfreie Prüfung - Radioskopische Prüfung - Teil 1:
Quantitative Messung der bildgebenden Eigenschaften

This European Standard was approved by CEN on 29 October 1999.

CEN members are bound to comply with the CEN/CENELEC Internal Regulations which stipulate the conditions for giving this European Standard the status of a national standard without any alteration. Up-to-date lists and bibliographical references concerning such national standards may be obtained on application to the Central Secretariat or to any CEN member.

This European Standard exists in three official versions (English, French, German). A version in any other language made by translation under the responsibility of a CEN member into its own language and notified to the Central Secretariat has the same status as the official versions.

CEN members are the national standards bodies of Austria, Belgium, Czech Republic, Denmark, Finland, France, Germany, Greece, Iceland, Ireland, Italy, Luxembourg, Netherlands, Norway, Portugal, Spain, Sweden, Switzerland and United Kingdom.



EUROPEAN COMMITTEE FOR STANDARDIZATION
COMITÉ EUROPÉEN DE NORMALISATION
EUROPÄISCHES KOMITEE FÜR NORMUNG

Central Secretariat: rue de Stassart, 36 B-1050 Brussels

Contents

Foreword	3
1 Scope	4
2 Normative references	4
3 Radioscopic system	4
4 Measurement of image quality parameters	5
Annex A (informative) Example for a test report according to EN 13068-1	22

Foreword

This European Standard has been prepared by Technical Committee CEN/TC 138 "Non-destructive testing", the secretariat of which is held by AFNOR.

This European Standard shall be given the status of a national standard, either by publication of an identical text or by endorsement, at the latest by June 2000, and conflicting national standards shall be withdrawn at the latest by June 2000.

According to the CEN/CENELEC Internal Regulations, the national standards organizations of the following countries are bound to implement this European Standard: Austria, Belgium, Czech Republic, Denmark, Finland, France, Germany, Greece, Iceland, Ireland, Italy, Luxembourg, Netherlands, Norway, Portugal, Spain, Sweden, Switzerland and the United Kingdom.

EN 13068 comprises a series of European Standards of radioscopic systems which is made of the following:

EN 13068-1:1999, *Non-destructive testing - Radioscopic testing - Part 1: Quantitative measurement of imaging properties.*

EN 13068-2:1999, *Non-destructive testing - Radioscopic testing - Part 2: Check of long term stability of imaging devices.*

prEN 13068-3, *Non-destructive testing - Radioscopic testing - Part 3: General principles of radioscopic testing of metallic materials by X- and gamma-rays.*

Annex A is informative.

1 Scope

The procedures given in this standard can be applied to all radiosopic systems which provide an electronic signal to a display unit or an automated image interpretation system. The radiosopic system is analysed for the response to well defined test specimen. The measurement should be performed by a sufficiently equipped laboratory.

From the results, the specifications of the imaging system regarding image properties can be derived.

This standard so far does not include imaging properties under moving conditions.

2 Normative references

This European Standard incorporates, by dated or undated reference, provisions from other publications. These normative references are cited at the appropriate places in the text and the publications are listed hereafter. For dated references, subsequent amendments to or revisions of any of these publications apply to this European standard only when incorporated in it by amendment or revision. For undated references the latest edition of the publication referred to applies.

EN 29241-2, *Ergonomic requirements for office work with visual display terminals (VDTs) - Part 2: Guidance on task requirements* (ISO 9241-2:1992)

EN 29241-3, *Ergonomic requirements for office work with visual display terminals (VDTs) - Part 3: Visual display requirements* (ISO 9241-3:1992)

3 Radioscopic system

In the context of this standard a radiosopic system consists of a radiation source, a handling system, collimators, filters and an imaging device.

An imaging device consists of an X- or gamma ray conversion device which transforms the radiation relief into an output signal S for numerical or optical presentation (see figure 1). Image processing systems can be part of the imaging device. In the case of visual evaluation it includes the display unit. In cases of fully automated image evaluation systems the display unit is not part of the system.

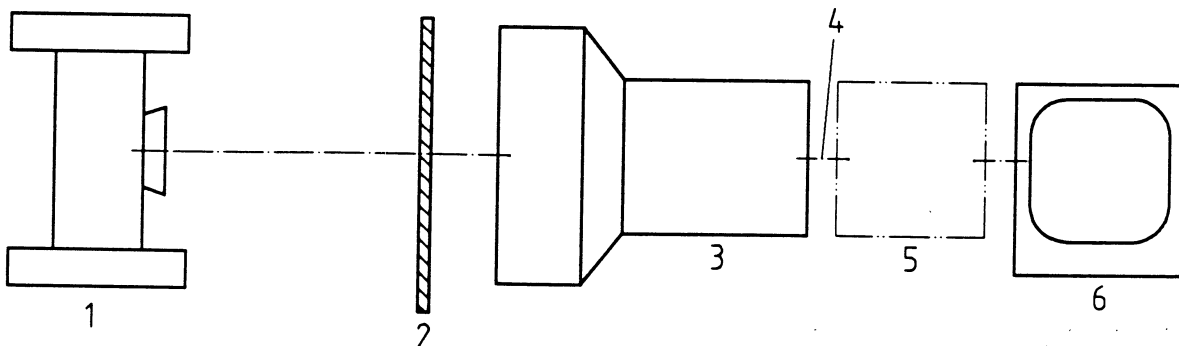

Key

- 1 Radiation source
- 2 Object
- 3 Radiation conversion device
- 4 Output signal
- 5 Image processing
- 6 Display unit

Figure 1 – Typical arrangement of an imaging device

For the specification of the imaging properties of imaging devices terms and parameters of information theory and radiographic testing are used. The parameters in table 1 define the image quality of imaging devices.

In some descriptions of image quality parameters the term "signal-to-noise-ratio (SNR)" is used. Within the meaning of information theory SNR is the ratio of the actual partial scale signal ΔS to rms-value S_{RMS} of the overlay noise signal, see figure 2.

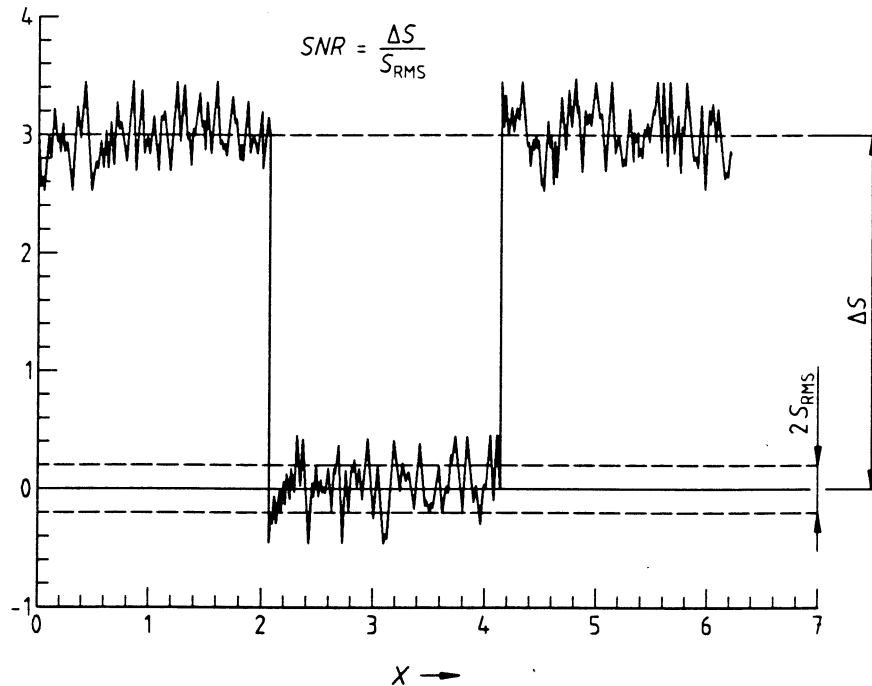

a Signal

Figure 2 – Determination of ΔS and S_{RMS} from output signal S

4 Measurement of image quality parameters

4.1 Principle

4.1.1 Conversion device

The basis of all measurements with the conversion device is the use of a defined radiation relief by artificial test indicators as an input signal and the measurement of the system response in the linear raw output signal with suitable measuring equipment (see figure 1). All measurements shall be done with the imaging device itself.

In figure 3 the principle set up for all measurements is shown. The radiation filter shall be placed in front of the X-ray tube. Collimators shall be used to reduce scattering radiation. All test indicators shall be placed in front of the input screen of the conversion device. They produce a defined radiation relief as an input signal. Measuring equipment shall be connected to the final output signal for measurement of the total system response.

For video signals the measuring equipment shall fulfill the following minimum requirements:

- Amplitude resolution ≥ 10 Bit;
- Time resolution ≥ 10 Bit = 1024 sample points;
- Bandwidth ≥ 50 MHz;
- Minimum sampling rate ≥ 100 MHz;
- Signal averaging function.

Table 1 – Image quality parameters

Image quality parameter	Definition	Explanation	Importance
Inherent unsharpness U_i	$U_i = s_c \cdot t_r$ $t_r = t_{50\%-\text{ESF}} - t_{10\%-\text{ESF}}$ overshoot $\leq 10\%$ with and	Inherent unsharpness is proportional to the rise time t_r of an edge spread function ESF from an intensity step function	Transmission limit for small object details
Spatial modulation transfer function MTF	$MTF(f_x) = \frac{1}{\int_{-\infty}^{\infty} LSF(x) dx} \left \int_{-\infty}^{\infty} LSF(x) \cdot e^{-2\pi i(xf_x)} dx \right $ $LSF(x) = \frac{dESF(x)}{dx}$	Magnitude spectrum of the Fourier-transformed and before differentiated spatial edge spread function ESF LSF : Line Spread Function	Contrast transmission as a function of object size; functional description of image sharpness
Contrast ratio C_o	$C_o = \frac{S_o}{S_{pb}}$	Ratio of the mean amplitude S_o without masking to the mean amplitude S_{pb} with 10 % masking of front screen	Description of far-reaching, contrast-reducing disturbing effects within the radioscopic system
Contrast sensitivity C_s	$C_s = \frac{\Delta w_{\min}}{w} \cdot 100\%$ with $\text{SNR} (\Delta w_{\min}) \geq 2$	Ratio of minimal transmitted wallthickness change Δw_{\min} to wallthickness w with SNR (Δw_{\min}) ≥ 2	Transmission limit for wallthickness changes as a function of wallthickness

Table 1 - Image quality parameters (concluded)

Image quality parameter	Definition	Explanation	Importance
Wallthickness range ΔW_o	$\Delta W_o = W_{max} - W_{min}$ $W_{max} = w \text{ for SNR} = 2$ $W_{min} = w \text{ for } S = S_{max}$ <p>with</p>	Difference of wall thicknesses which give a useful video signal	Maximum wall thickness range which can be viewed within one image
Differential and integral distortion $V_{d,i}$	$V_{d,i} = \left(\frac{s_{i,d}}{s_c} - 1 \right) \cdot 100 \text{ in } \%$	Ratio of local (diameter) dependent representation scale $s_{i,d}$ to central representation scale s_c	Description of the geometric distortions
Differential and integral image homogeneity $H_{d,i}$	$H_d = \frac{S_{max}}{S_{RMS-SN}}$ $H_i = \frac{S(x,y)}{S_{max}} \cdot 100 \text{ in } \%$	ratio of maximum video amplitude S_{max} to RMS-value S_{RMS-SN} of "spatial" noise; Ratio of local video amplitude $S(x,y)$ to S_{max} with a homogeneous intensity distribution at input screen	Description of local and integral spatial variance of contrast transmission (shading)

Because image quality parameters are dependent on radiation energy and quality, measurements shall be done in the lower, middle and upper part of a permissible energy range of the radioscopic system with constant potential X-ray equipment. In order to guarantee a defined radiation quality, the radiation filtering shall be used as given in table 2. The tube current shall be adjusted to give a dose rate of 0,01 mGy/min; 0,1 mGy/min; 1,0 mGy/min or 10 mGy/min at the input plane of the conversion device.

Table 2 – Radiation filtering for system measurement

Tube voltage kV	Radiation filter thickness and material ^{a)} mm
50	7 ± 0,5 Al
100	22 ± 0,5 Al
150	7 ± 0,5 Cu
200	12 ± 0,5 Cu
300	15 ± 0,5 Cu
400	25 ± 0,5 Cu
> 400	35 ± 0,5 Cu

^{a)} The purity of the filter material should be better than 99 %

During measurements the radioscopic system shall be operated in accordance with the instruction manual and manufacturer's instructions. The radiation intensity shall be adjusted to such a value that in the middle of the input screen behind the radiation filter (without any test specimen) the output signal S shows the maximum signal amplitude S_{\max} . The radiation intensity shall be measured with an ionization chamber in the middle in front of the input screen and documented together with all other measuring results.

X-ray detectors should have a sufficient period of use (e. g. for X-ray image intensifiers 1 Gy) before the measurements are made.

4.1.2 Display unit and image processor

For assessment of display units and image processors the following procedure is recommended.

A bar pattern is generated by an electronic test pattern generator according to the requirements 4.1.1 for measuring equipment (according to EN 29241-2 and EN 29241-3). The generator shall be able to produce vertical bars up to the limiting band width of the display unit or image processor.

The bar pattern is displayed on the image display unit. For evaluation a small section (max. 10 % of the total display area) is picked up by an optical sensor. The result is digitized. Suitable optical sensors are TV cameras or linear line-scan cameras. The magnification scale shall be at least 10. Therefore, at least 10 pixels in the frame buffer are available for the presentation of 1 pixel on the TV monitor. Beating effects between the pixel frequencies of the display unit and camera can be compensated by signal integration.

4.2 Measurement procedures

4.2.1 Conversion device

4.2.1.1 Sharpness (spatial resolution)

In order to characterize the system sharpness the following three image quality parameters shall be measured:

a) Inherent unsharpness

For measurement of the inherent unsharpness U_i (see equation (2)) an intensity step function shall be produced by a sharp edge of absorbent material (figure 4). The image of the edge shall be located in the centre of the input screen perpendicular and horizontal to the read out line of the detector. The radiation intensity shall be adjusted by the tube current according to the selected values as given in 4.1. In order to reduce the effect of scattered radiation the input screen shall be covered by absorbing material whereby approximately 10 % of the input screen should be irradiated only.

The system shall be adjusted such that the output signal shows a black-to-white signal (Edge Spread Function ESF) with a minimum signal amplitude of 90 % of the maximum electronic signal amplitude and an overshoot less than 10 %. The inherent unsharpness is proportional to the rise time t_r of the edge spread function. If there is an adjustable diaphragm the setting shall be stated in the protocol.

A second measurement will give the value for the scale factor s_c in order to calculate the inherent unsharpness in millimetres (figure 5). The edge shall be substituted by a test indicator with well-known length l and the corresponding dimension (time interval for an output signal) x_l shall be measured (see equation (1)).

$$S_c = \frac{l}{X_l} \quad (1)$$

$$U_l = s_c \cdot t_r \quad \text{with overshoot} \leq 10 \% \quad (2)$$

with

$$t_r = t_{90\% - \text{ESF}} - t_{10\% - \text{ESF}}$$

b) Spatial modulation transfer function (MTF)

The starting point for the calculation of the MTF is the edge spread function from the former unsharpness measurement (figure 6). The edge spread function shall be digitized with high resolution and stored in a computer. The sampling theorem shall be considered. In the next step the ESF shall numerically be differentiated in order to get the Line Spread Function LSF. The magnitude spectrum of the Fourier-transformed LSF will give the MTF. For a common representation of MTF curve the modulation m for the spatial frequency $f = 0$ Lp/mm shall be normalized to $m = 1$. If possible the vertical MTF can be determined by using the unmodified grey values taken from a digital image processing system.

c) Contrast ratio for low spatial frequencies

To measure the contrast ratio C_o at first the input screen shall be irradiated with a uniform radiation relief without any mask (figure 7). The mean signal amplitude S_o in the middle of the input screen area shall be measured. In the next step 10 % of the input screen area shall be covered with an absorbent mask in the centre and again the mean amplitude S_{pb} of the electronic signal behind the mask shall be measured. The absorbent mass shall reduce the intensity of the radiation by a factor 1000.

$$C_o = S_o / S_{pb} \quad (3)$$

4.2.1.2 Contrast

The exposure time per frame, the number of integrated frames and the dose rate shall be stated in the protocol. Contrast properties of the radioscopic system are described by the following image quality parameters:

a) Contrast sensitivity

For producing the radiation relief with decreasing radiation contrast a steel plate of thickness d in combination with a step wedge (steel) on the source side of the plate shall be positioned in front of the input screen (figure 8). The step wedge shall be positioned in the direction of the read out line of the detector and in the centre of the input screen. In the output signal the signal-to-noise-ratio SNR of each step wedge shall be measured. The thinnest step with a $\text{SNR} \geq 2$ shall be regarded as the minimal detectable wall thickness change Δw_{\min} .

$$S = \Delta w_{\min} / w \quad (4)$$

In order to reduce the influence of quantum noise the feature of signal averaging shall be used.

b) Wall thickness range

At the beginning of the measurement radiation parameter like energy and tube current shall be defined and fixed. Only a small part (~ 10 %) of the front screen shall be irradiated in order to reduce scattering effects. In front of the input screen a step-like test indicator with a step height of ~ 1 mm shall be placed (figure 9). The thinnest step w_{\min} which gives the maximum amplitude S_{\max} of the output signal shall be the starting point of the measurement. The test indicator shall be shifted step by step in the direction of the thicker part.

For each step the corresponding signal amplitude shall be measured until the SNR is ≤ 2 . In order to reduce the influence of quantum noise the feature of signal averaging shall be used.

The difference of wall thickness between thinnest and thickest wall thickness w_{\min} , w_{\max} is the wall thickness range Δw_o (equation (5)).