

Handläggande organ	Fastställt	Utgåva	Sida
SVENSK MATERIAL- & MEKANSTANDARD, SMS	1997-11-21	1	1 (1+13)

SIS FASTSTÄLLER OCH UTGER SVENSK STANDARD SAMT SÄLJER NATIONELLA, EUROPEISKA OCH INTERNATIONELLA STANDARDPUBLIKATIONER ©

Technical drawings – Roller bearings – Part 2: Detailed simplified representation (ISO 8826-2:1994)

The European Standard EN ISO 8826-2:1997 has the status of a Swedish Standard. This document contains the official English version of EN ISO 8826-2:1997.

Swedish Standards corresponding to documents referred to in this Standard are listed in "Catalogue of Swedish Standards", issued by SIS. The Catalogue lists, with reference number and year of Swedish approval, International and European Standards approved as Swedish Standards as well as other Swedish Standards.

Ritregler – Rullningslager – Del 2: Detaljerad förenklad ritning (ISO 8826-2:1994)

Europastandarden EN ISO 8826-2:1997 gäller som svensk standard. Detta dokument innehåller den officiella engelska versionen av EN ISO 8826-2:1997.

Motsvarigheten och aktualiteten i svensk standard till de publikationer som omnämns i denna standard framgår av "Katalog över svensk standard", som ges ut av SIS. I katalogen redovisas internationella och europeiska standarder som fastställts som svenska standarder och övriga gällande svenska standarder.

ICS 01.100.20; 21.100.20

Standarder kan beställas hos SIS som även lämnar allmänna upplysningar om svensk och utländsk standard.
Postadress: SIS, Box 6455, 113 82 STOCKHOLM
Telefon: 08 - 610 30 00. Telefax: 08 - 30 77 57

Upplysningar om **sakinnehållet** i standarden lämnas av SMS.
Telefon: 08 - 459 56 00. Telefax: 08 - 667 85 42
E-post: info@sms-standard.se
Prisgrupp P

Tryckt i januari 1998

EUROPEAN STANDARD
NORME EUROPÉENNE
EUROPÄISCHE NORM

EN ISO 8826-2

October 1997

ICS 01.100.20; 21.100.20

Descriptors: drawings, technical drawings, bearings, rolling bearings, graphic methods

English version

**Technical drawings – Rolling bearings – Part 2: Detailed
simplified representation (ISO 8826-2:1994)**

Dessins techniques – Roulements – Partie 2:
Représentation simplifiée particulière
(ISO 8826-2:1994)

Technische Zeichnungen – Wälzlager – Teil 2:
Detaillierte vereinfachte Darstellung
(ISO 8826-2:1994)

This European Standard was approved by CEN on 12 September 1997.

CEN members are bound to comply with the CEN/CENELEC Internal Regulations which stipulate the conditions for giving this European Standard the status of a national standard without any alteration. Up-to-date lists and bibliographical references concerning such national standards may be obtained on application to the Central Secretariat or to any CEN member.

The European Standards exist in three official versions (English, French, German). A version in any other language made by translation under the responsibility of a CEN member into its own language and notified to the Central Secretariat has the same status as the official versions.

CEN members are the national standards bodies of Austria, Belgium, Czech Republic, Denmark, Finland, France, Germany, Greece, Iceland, Ireland, Italy, Luxembourg, Netherlands, Norway, Portugal, Spain, Sweden, Switzerland and United Kingdom.

CEN

European Committee for Standardization
Comité Européen de Normalisation
Europäisches Komitee für Normung

Central Secretariat: rue de Stassart 36, B-1050 BRUSSELS

Foreword

The text of the International Standard from Technical Committee ISO/TC 10 "Technical drawings, product definition and related documentation" of the International Organization for Standardization (ISO) has been taken over as an European Standard by CEN/CS.

This European Standard shall be given the status of a national standard, either by publication of an identical text or by endorsement, at the latest by April 1998, and conflicting national standards shall be withdrawn at the latest by April 1998.

According to the CEN/CENELEC Internal Regulations, the national standards organizations of the following countries are bound to implement this European Standard: Austria, Belgium, Czech Republic, Denmark, Finland, France, Germany, Greece, Iceland, Ireland, Italy, Luxembourg, Netherlands, Norway, Portugal, Spain, Sweden, Switzerland and the United Kingdom.

Endorsement notice

The text of the International Standard ISO 8826-2:1994 has been approved by CEN as a European Standard without any modification.

NOTE: Normative references to International Standards are listed in annex ZA (normative).

Technical drawings — Rolling bearings —

Part 2: Detailed simplified representation

1 Scope

This part of ISO 8826 specifies a detailed simplified representation for various rolling bearings. This representation should be used in cases where it is not necessary to show the exact shape and details of the rolling bearings, for example in assembly drawings.

2 Normative references

The following standards contain provisions which, through reference in this text, constitute provisions of this part of ISO 8826. At the time of publication, the editions indicated were valid. All standards are subject to revision, and parties to agreements based on this part of ISO 8826 are encouraged to investigate the possibility of applying the most recent editions of the standards indicated below. Members of IEC and ISO maintain registers of currently valid International Standards.

ISO 15:1981, *Rolling bearings — Radial bearings — Boundary dimensions — General plan.*

ISO 104:—¹⁾, *Rolling bearings — Thrust bearings — Boundary dimensions, general plan.*

ISO 355:1977, *Rolling bearings — Metric tapered roller bearings — Boundary dimensions and series designations.*

ISO 582:—²⁾, *Rolling bearings — Metric series — Chamfer dimension limits.*

ISO 1206:1982, *Needle roller bearings — Light and medium series — Dimensions and tolerances.*

ISO 3030:1974, *Needle roller bearings — Needle roller and cage assemblies — Metric series — Part 1: Radial needle roller and cage assemblies — Boundary dimensions and tolerances.*

ISO 3031:1979, *Needle roller bearings — Thrust needle roller and cage assemblies, thrust washers — Dimensions and tolerances.*

ISO 3245:1974, *Rolling bearings — Needle roller bearings, drawn cup, without inner ring — Metric series — Boundary dimensions and tolerances.*

ISO 8443:1985, *Radial ball bearings with flanged outer ring — Flange dimensions.*

ISO 8826-1:1989, *Technical drawings — Rolling bearings — Part 1: General simplified representation.*

ISO 9628:1992, *Rolling bearings — Insert bearings and eccentric locking collars.*

1) To be published. (Revision of ISO 104:1979)

2) To be published. (Revision of ISO 582:1979)

3 Method of representation

3.1 General rules

See ISO 8826-1.

The space on a drawing where a rolling bearing is located shall be circumscribed by means of a square or rectangle (even if there is no inner or outer ring respectively).

3.2 Elements of detailed simplified representation for rolling bearings

The elements of detailed simplified representation for rolling bearings are given in table 1.

Examples of combinations of bearing features (according to table 1) and load-bearing characteristics are given in table 2.

In representations perpendicular to the bearing axis, the rolling element may be shown as a circle, regardless of its actual shape (ball, roller, needle, etc.) and size (see figure 1).

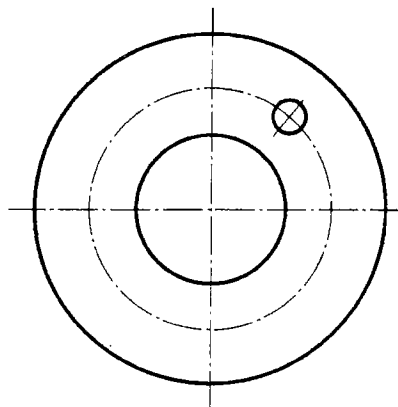







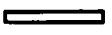
Figure 1

3.3 Detailed simplified representation

The detailed simplified representation of rolling bearings is shown in tables 3 to 6.

Roller bearings shown in tables 3 to 5 are always depicted in the space above the horizontal axis of the bearing, while table 6 refers to the vertical axis of the bearing.

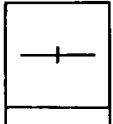
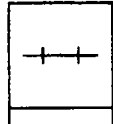
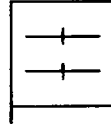
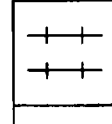
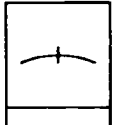

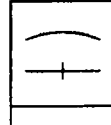
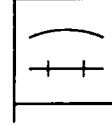
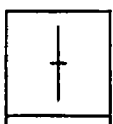
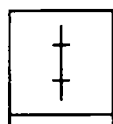
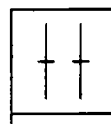
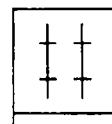
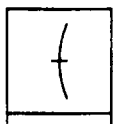
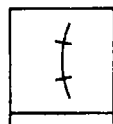
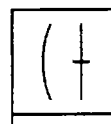
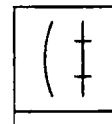
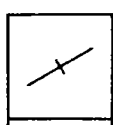
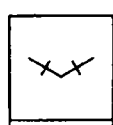
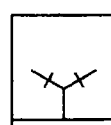
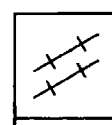

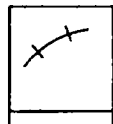
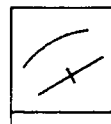
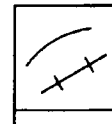
Table 1 — Elements of detailed simplified representation for rolling bearing features

No.	Element	Description	Application		
1.1		Long continuous straight line	Line representing the axis of the rolling element, without possibility of alignment		
1.2		Long continuous arc of circle	Line representing the axis of the rolling element, with possibility of alignment		
1.3	Alternative indication (examples)		Short continuous straight line, crossing the long continuous line No. 1.1 or 1.2 at 90° (preferred simplified indication) coincident with the centreline (radial) of each rolling element.	Number of rows and position of the rolling elements	
			circle		ball
			wide rectangle		roller
			narrow rectangle		needle-roller, pin

1) This element may be shown inclined, depending on the type of the bearing.



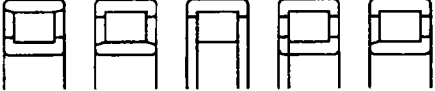













2) Instead of the short continuous straight line, this variation may be used to represent the rolling element.

Table 2 — Combination of elements in detailed simplified representation

Load-bearing characteristics			Bearing features				
			Two rings		Three rings		
			One row	Two rows	One row	Two rows	
Direction of load	Radial	Alignment	no				
		yes					
	Axial	Alignment	no				
		yes					
	Radial and axial	Alignment	no				
		yes					

NOTE — The rolling bearings shown in this table are always depicted on the drawing in the space above the bearing axis.

Table 3 — Ball and roller bearings

Detailed simplified representation		Application	
		Ball bearings	Roller bearings
		Illustration ¹⁾ and reference ²⁾	Illustration ¹⁾ and reference ²⁾
3.1		 Deep groove ball bearing, single row ISO 15, ISO 8443 Insert bearing ISO 9628	 Cylindrical roller bearing, single row ISO 15
3.2		 Deep groove ball bearing, double row ISO 15	 Cylindrical roller bearing, double row ISO 15
3.3			 Spherical roller bearing, single row ISO 15
3.4		 Ball bearing, self-aligning, double row ISO 15	 Spherical roller bearing, double row ISO 15
3.5		 Separable ball bearing, angular contact, single row ISO 582	 Tapered roller bearing, angular contact, single row ISO 355
3.6		 Non-separable ball bearing, angular contact, double row	